

+ **acumed**[®]
Ankle Plating System 3



Acumed Small Fragment
Base Set Required



Acumed Variable Angle
Screw Compatible

Surgical Technique

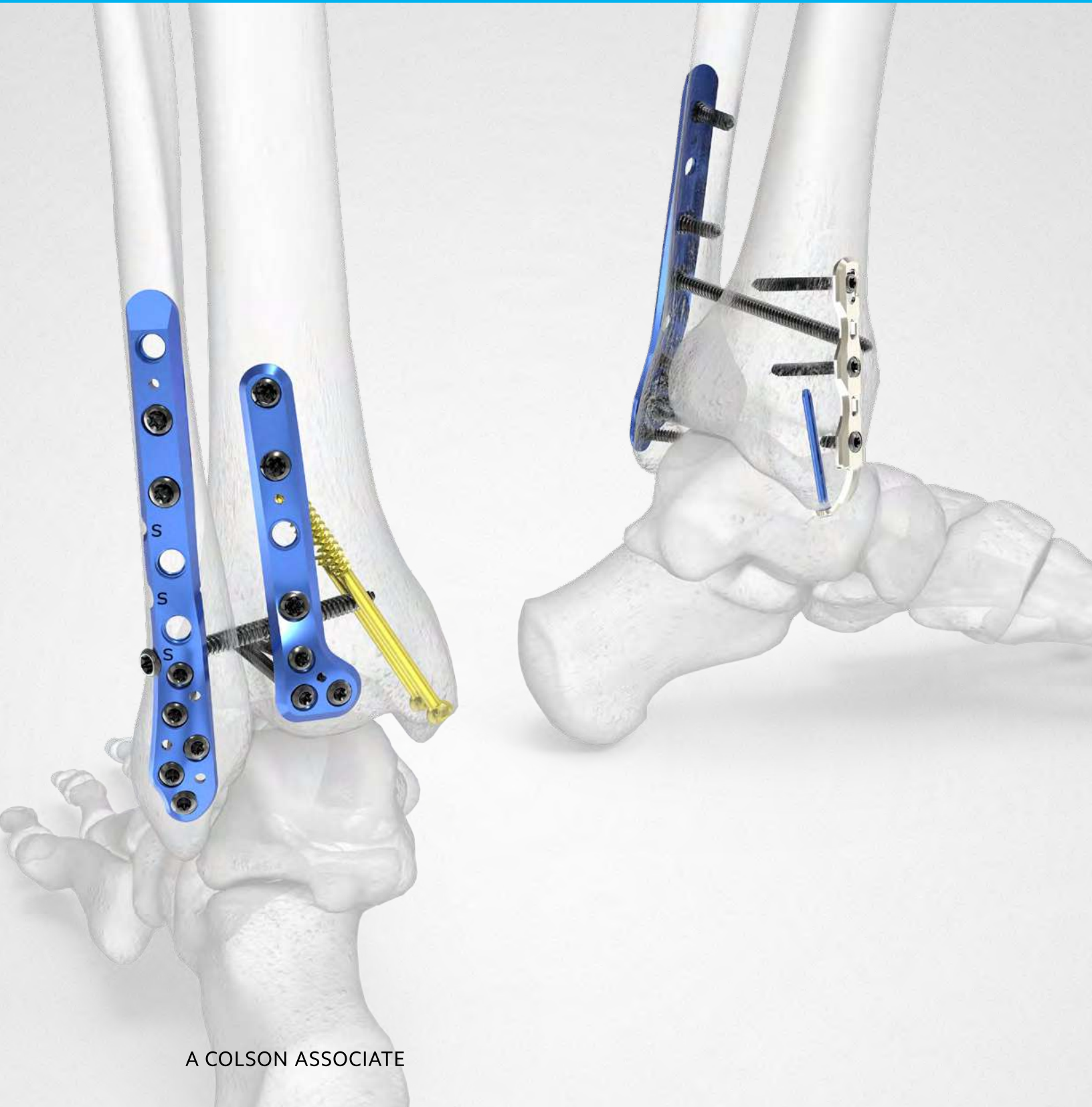

Acumed® is a global leader of innovative orthopaedic and medical solutions.



We are dedicated to developing products, service methods, and approaches that improve patient care.

Acumed® Ankle Plating System 3

The Acumed Ankle Plating System 3 is designed to provide a variety of fixation options for rotational fractures of the distal tibia and fibula.

Designed in conjunction with Anish Kadakia, MD and Bruce Ziran, MD, the Ankle Plating System 3 includes seven plate families designed specifically for the treatment of ankle fractures. The indication-specific plates address fracture patterns of the medial, lateral, and posterior malleoli. Specialized plate features and unique instrumentation address disruption of the syndesmosis. 4.0 mm cannulated screws in lengths of 36 mm, 42 mm, and 48 mm are included in the Ankle 3 tray for the treatment of medial malleolar fractures. In addition, both short thread and long thread 4.0 mm cannulated screws ranging in length from 10 mm to 72 mm are available. These screws are housed in a standalone tray and use the 4.0 mm cannulated screw instruments within the Ankle Plating System 3.

The Ankle Plating System 3 is used in combination with the Acumed Small Fragment Base Set. The Small Fragment Base Set includes One-Third Tubular Plates, as well as cut-to-length and bend-to-fit 2.7 mm L-shaped, T-shaped, and straight Fragment Plates that can also be used to address ankle fractures. The 2.7 mm and 3.5 mm nonlocking, locking, and variable angle hexalobe screws, 4.0 mm fully threaded and partially threaded cancellous hexalobe screws, and universal instrumentation are all housed within the Small Fragment Base Set. A selection of Tension Band Pins and AcuTwist® Compression Screws are also included.

Indications for Use:

The Acumed Ankle Plating System 3 includes orthopaedic implants with the following indications:

Lateral Fibula Plates, Posterolateral Fibula Plates, Posteromedial Distal Tibia Plates, Posterolateral Distal Tibia Plates, and Medial Anti-Glide Plates are intended for use for fixation of fractures, osteotomies, and nonunions of the distal tibia and fibula, particularly in osteopenic bone.

Hook Plates and Locking Peg Hook Plates are intended for fixation of fractures, osteotomies, and nonunions of small bones, including the tibia and fibula.

The Acumed Cannulated Screw System is generally intended for fixation of fractures, fusions, and osteotomies of large and small bones appropriate for the size of the device.

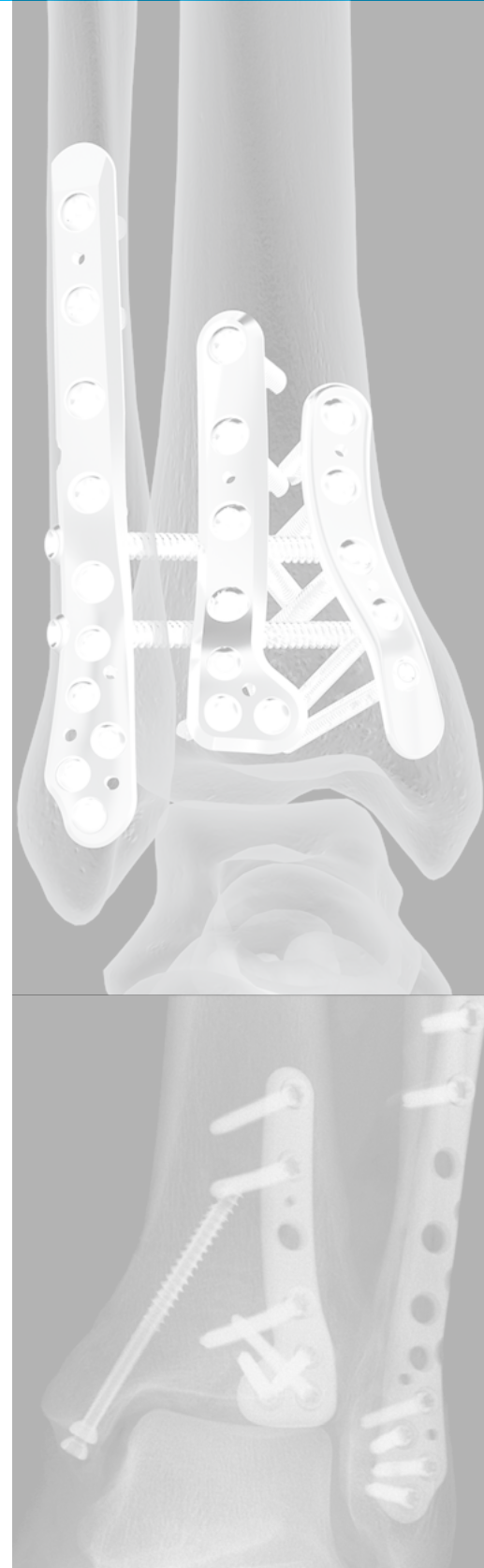















	Definition
Warning	Indicates critical information about a potential serious outcome to the patient or the user.
Caution	Indicates instructions that must be followed in order to ensure the proper use of the device.
Note	Indicates information requiring special attention.
	Products with this symbol require use of the Acumed Small Fragment Base Set in order to complete surgery following the recommended surgical technique.
	Products with this symbol are compatible with Acumed 2.7 mm and 3.5 mm Variable Angle Screws for use in completing surgery following the recommended surgical technique.

Table of Contents

Ankle Plating System 3 Features	2
Implants	2
Instrumentation	6
Small Fragment Base Set Features	7
Acumed® Variable Angle Screws.....	11
Surgical Technique Overview.....	14
Surgical Techniques	18
Lateral Fibula Plate Surgical Technique	18
Posterolateral Fibula Plate Surgical Technique	22
Posterolateral Distal Tibia Plate Surgical Technique.....	27
Posteromedial Distal Tibia Plate Surgical Technique	30
Medial Anti-Glide Plate Surgical Technique	34
Hook Plate Surgical Technique	37
Locking Peg Hook Plate Surgical Technique.....	39
Variable Angle Screw Surgical Technique	42
4.0 mm Cannulated Screw Surgical Technique.....	46
Ordering Information	48
References	55

Ankle Plating System 3 Features

Lateral Fibula Plates

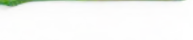
-  **4-Hole 74 mm**
(7007-0104L)
-  **5-Hole 86 mm**
(7007-0105L)
-  **6-Hole 103 mm**
(7007-0106L)
-  **7-Hole 115 mm**
(7007-0107L)
-  **9-Hole 135 mm**
(7007-0109L)
-  **11-Hole 164 mm**
(7007-0111L)*
-  **13-Hole 188 mm**
(7007-0113L)*
-  **13-Hole 188 mm**
(7007-0113R)*
-  **11-Hole 164 mm**
(7007-0111R)*
-  **9-Hole 135 mm**
(7007-0109R)
-  **7-Hole 115 mm**
(7007-0107R)
-  **6-Hole 103 mm**
(7007-0106R)
-  **5-Hole 86 mm**
(7007-0105R)
-  **4-Hole 74 mm**
(7007-0104R)



Proximal screw holes accept:
 3.5 mm locking hexalobe screws
 3.5 mm nonlocking hexalobe screws
 3.5 mm variable angle hexalobe screws
 4.0 mm fully threaded cancellous hexalobe screws

Slot accepts:
 3.5 mm nonlocking hexalobe screw
 4.0 mm fully threaded cancellous hexalobe screws

Distal cluster accepts:
 2.7 mm locking hexalobe screws
 2.7 mm nonlocking hexalobe screws
 2.7 mm variable angle hexalobe screws

These plates are designed with a thin distal taper aimed to limit screw head prominence and soft tissue irritation

Lateral Fibula Plates contain two holes labeled with an "S" for syndesmosis—these holes are angled 30° anterior to target the center of the tibia

"S" marked screw holes accept:
 3.5 mm locking hexalobe screws
 3.5 mm nonlocking hexalobe screws

***Please note:** The 11-hole and 13-hole Lateral Fibula Plates are only available sterile-packed and are not housed in the Ankle Plating System 3 tray.

Ankle Plating System 3 Features [continued]

Posterolateral Fibula Plates

-  **3-Hole 66 mm**
(7007-0203L)
-  **4-Hole 78 mm**
(7007-0204L)
-  **5-Hole 90 mm**
(7007-0205L)
-  **6-Hole 102 mm**
(7007-0206L)
-  **7-Hole 116 mm**
(7007-0207L)
-  **7-Hole 116 mm**
(7007-0207R)
-  **6-Hole 102 mm**
(7007-0206R)
-  **5-Hole 90 mm**
(7007-0205R)
-  **4-Hole 78 mm**
(7007-0204R)
-  **3-Hole 66 mm**
(7007-0203R)

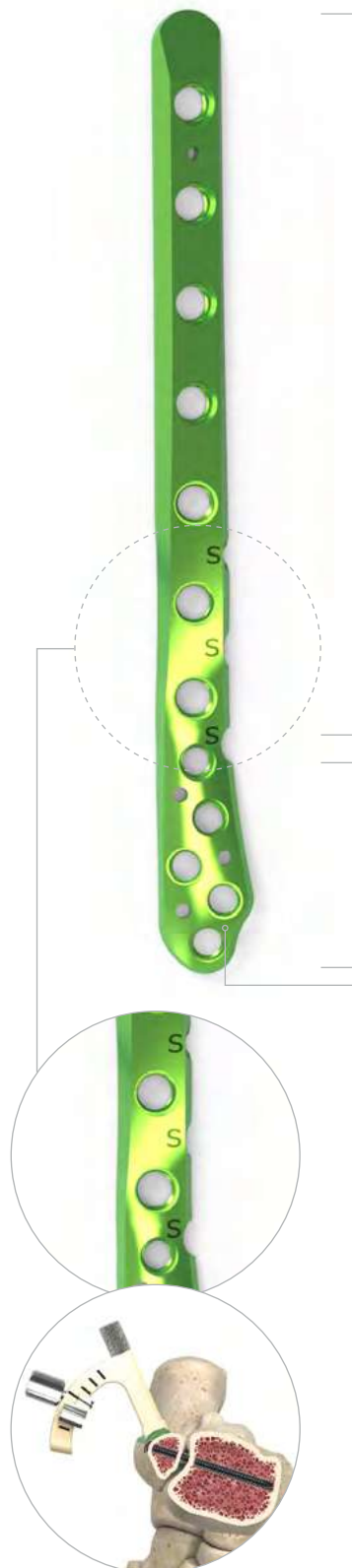

Proximal screw holes accept:
 3.5 mm locking hexalobe screws
 3.5 mm nonlocking hexalobe screws
 3.5 mm variable angle hexalobe screws
 4.0 mm fully threaded cancellous hexalobe screws

Distal cluster accepts:
 2.7 mm locking hexalobe screws
 2.7 mm nonlocking hexalobe screws
 2.7 mm variable angle hexalobe screws

The thin distal plate end is designed to limit soft tissue irritation of the peroneal tendons

Posterolateral Fibula Plates contain three scallops to allow 3.5 mm nonlocking hexalobe screw placement adjacent to the plate at 1, 2, or 3 cm above the tibial plafond for syndesmosis fixation

Ankle Plating System 3 Features [continued]

Posterior Distal Tibia Plates



Published literature suggests that ankle fractures with involvement of the posterior malleolus are both underestimated and underdiagnosed.¹ Fractures involving the posterior malleolus tend to lead to poorer outcomes even when the fragment is small, with worse outcomes as the fragment size increases.²

The Acumed Ankle Plating System 3 incorporates unique plating options for both the posteromedial and posterolateral aspect of the distal tibia to specifically address these difficult fracture patterns.



Posterolateral Distal Tibia Plates

The Posterolateral Distal Tibia Plates are designed to treat posterior malleolus fractures and act as a template to aid in anatomic fracture reduction.

	3-Hole 48 mm (7007-0303L)		Proximal screw holes accept: 3.5 mm locking hexalobe screws 3.5 mm nonlocking hexalobe screws 3.5 mm variable angle hexalobe screws 4.0 mm fully threaded cancellous hexalobe screws
	4-Hole 60 mm (7007-0304L)		
	4-Hole 60 mm (7007-0304R)		
	3-Hole 48 mm (7007-0303R)		

Distal cluster accepts:
2.7 mm locking hexalobe screws
2.7 mm nonlocking hexalobe screws
2.7 mm variable angle hexalobe screws

Distal screws are angled 15° superior to avoid joint space

Thin distal plate end designed to limit soft tissue irritation of the flexor hallucis longus (FHL) tendon

Posteromedial Distal Tibia Plates

The Posteromedial Distal Tibia Plates are designed for the treatment of a posterior pilon variant. Switaj, et al characterize this fracture pattern as “a posteromedial fragment involving a portion of the medial malleolus, in combination with a posterolateral fragment.”¹ This plate sits under the posterior tibial tendon and is often used in conjunction with a Posterolateral Distal Tibia Plate.

	3-Hole 49 mm (7007-0403L)		Proximal screw holes accept: 3.5 mm locking hexalobe screws 3.5 mm nonlocking hexalobe screws 3.5 mm variable angle hexalobe screws 4.0 mm fully threaded cancellous hexalobe screws
	3-Hole 49 mm (7007-0403R)		

Distal screw holes accept:
2.7 mm locking hexalobe screws
2.7 mm nonlocking hexalobe screws
2.7 mm variable angle hexalobe screws

The thin distal plate end is designed to act as a buttress to distal fragments and aims to limit soft tissue irritation of the posterior tibial tendon

Ankle Plating System 3 Features [continued]

Hook Plates

The two prongs at the distal end of the Hook Plate are designed to support an avulsion fragment.



2-Hole 43 mm
(7007-0602)

3-Hole 57 mm
(7007-0603)



Slot accepts:
2.7 mm nonlocking hexalobe screws

Threaded screw holes accept:
2.7 mm locking hexalobe screws
2.7 mm nonlocking hexalobe screws
2.7 mm variable angle screws

Distal prongs designed to
buttress avulsion fragment



Locking Peg Hook Plates

The Locking Peg Hook Plates are designed to support an avulsion fragment that may require additional stability. The plate includes a 2.3 mm cortical peg for fixation across the fracture site.



2-Hole 45 mm
(7007-0702)

3-Hole 59 mm
(7007-0703)



Slot accepts:
2.7 mm nonlocking hexalobe screws

Threaded screw holes accept:
2.7 mm locking hexalobe screws
2.7 mm nonlocking hexalobe screws
2.7 mm variable angle hexalobe screws

Distal hole accepts only
2.3 mm Cortical Pegs



Medial Anti-Glide Plate

The Medial Anti-Glide Plate is designed to address vertical shear fractures of the medial malleolus. The plate includes a distal hole cluster for 2.7 mm screws to capture fragments in cases with distal comminution.



4-Hole 70 mm
(7007-0504)



Proximal screw holes accept:
3.5 mm locking hexalobe screws
3.5 mm nonlocking hexalobe screws
3.5 mm variable angle hexalobe screws
4.0 mm fully threaded cancellous screws

Distal cluster accepts:
2.7 mm locking hexalobe screws
2.7 mm nonlocking hexalobe screws
2.7 mm variable angle hexalobe screws



Ankle Plating System 3 Features [continued]

Syndesmosis Targeting Guide

The Syndesmosis Targeting Guide attaches to the Posterolateral Fibula Plate and allows the surgeon to choose the desired angle for syndesmotic screw fixation.

- ▶ Target location for syndesmosis screws is at the center of the tibia, through the fibula, 1 to 3 centimeters above the tibial plafond³
- ▶ Three plate scallops are placed at 1, 2, and 3 cm above the tibial plafond for preferred 3.5 mm nonlocking hexalobe syndesmotic screw fixation



Hook Plate Reduction Handle

- ▶ Attaches to the Hook Plates and Locking Peg Hook Plates
- ▶ Aids in reduction and controlling plate placement
- ▶ The attached cannulated bolt threads into the most distal plate hole

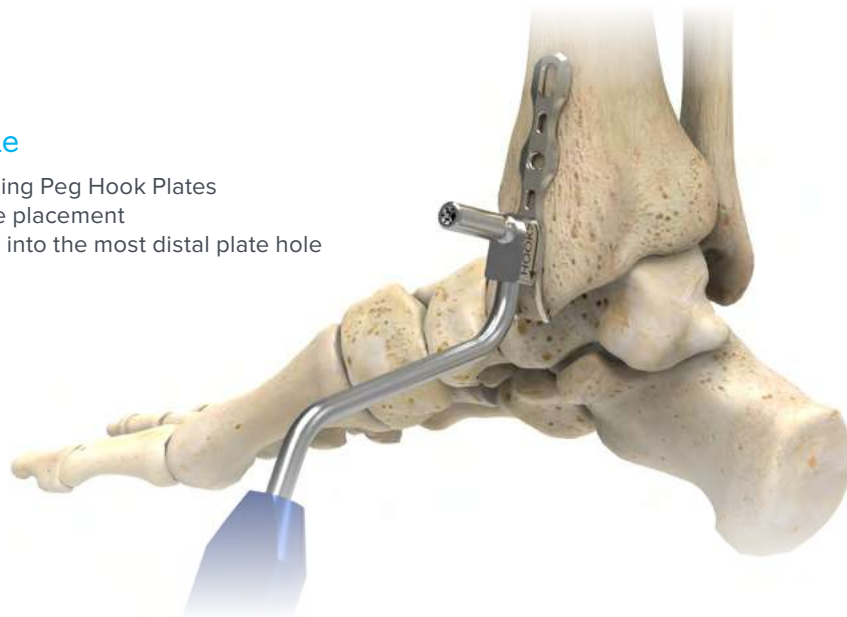

4.0 mm Cannulated Screws

System	Specifications
Ankle Plating System 3	36 mm Long Thread (1/2 Threaded) 42 mm Long Thread (1/2 Threaded) 48 mm Long Thread (1/2 Threaded)
Standalone 4.0 mm Cannulated Screw Caddies	10–72 mm Short Thread (1/3 threaded) 16–72 mm Long Thread (1/2 threaded) 10–60 mm (2 mm increments) 60–72 mm (4 mm increments)

Small Fragment Base Set Features

The Acumed Small Fragment Base Set contains One-Third Tubular Plates available in a variety of lengths as well as 2.7 mm L-shaped, T-shaped, and straight Fragment Plates to treat small bone fractures and malunions. Plates are designed to minimize soft tissue irritation.

One-Third Tubular Plates



One-Third Tubular Plate 3-Hole 37 mm
(7008-0103)



One-Third Tubular Plate 7-Hole 85 mm
(7008-0107)



One-Third Tubular Plate 4-Hole 49 mm
(7008-0104)



One-Third Tubular Plate 8-Hole 97 mm
(7008-0108)



One-Third Tubular Plate 5-Hole 61 mm
(7008-0105)

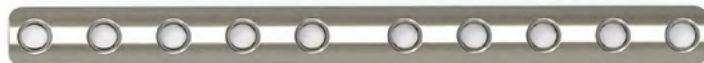

One-Third Tubular Plate 10-Hole 121 mm
(7008-0110)



One-Third Tubular Plate 6-Hole 73 mm
(7008-0106)



One-Third Tubular Plate 12-Hole 145 mm
(7008-0112)

Small Fragment Base Set Features [continued]

2.7 mm Fragment Plates



Fragment Plate 2.7 mm, 60 mm
(7010-0106N)



L Fragment Plate 2.7 mm Right, 61 mm
(7010-0107R)



L Fragment Plate 2.7 mm Left, 61 mm
(7010-0107L)



T Fragment Plate 2.7 mm, 61 mm
(7010-0108N)

Washers



Cannulated Screw Washers
7.0 mm Outer Dimension (OD) x 3.6 mm Inner Dimension (ID)
(7003-07036)

Screw Options

The following screws included in the Small Fragment Base Set also support Acumed Ankle Plating System 3 implants. These screws feature a hexalobe recess and are designed to have greater torsional strength in comparison to similar size hex screws.

2.7 mm and 3.5 mm Variable Angle Hexalobe Screws



2.7 mm and 3.5 mm Nonlocking Hexalobe Screws

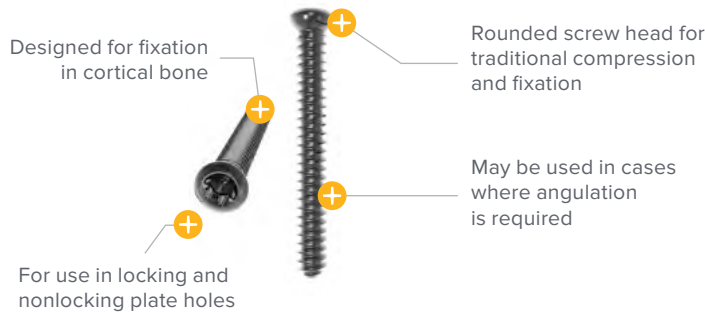

2.7 mm and 3.5 mm Locking Hexalobe Screws

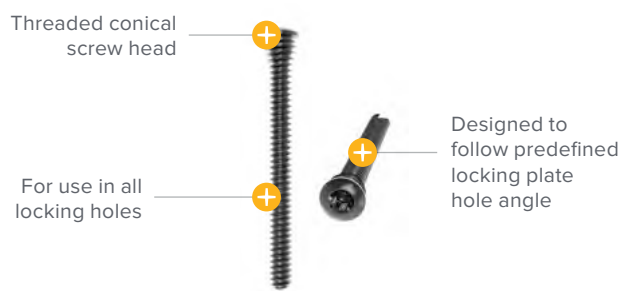

4.0 mm Partially Threaded Cancellous Hexalobe Screws



4.0 mm Fully Threaded Cancellous Hexalobe Screws

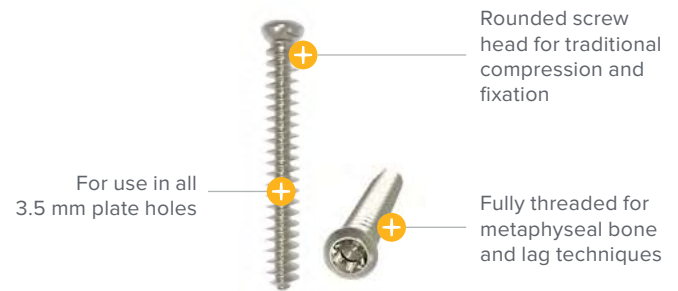

Screw Type	Material	Available Lengths	
		(2 mm increments)	(5 mm increments)
2.7 mm Variable Angle Hexalobe Screws	Cobalt Chrome	10–50 mm	50–60 mm
3.5 mm Variable Angle Hexalobe Screws		10–50 mm	50–65 mm
2.7 mm Locking Hexalobe Screws	Titanium	8–50 mm	50–60 mm
3.5 mm Locking Hexalobe Screws		8–50 mm	50–65 mm
2.7 mm Nonlocking Hexalobe Screws		8–50 mm	50–60 mm
3.5 mm Nonlocking Hexalobe Screws		8–50 mm	50–65 mm
4.0 mm Partially Threaded Cancellous Hexalobe Screws		12–30 mm	30–60 mm
4.0 mm Fully Threaded Cancellous Hexalobe Screws		10–30 mm	30–60 mm

Screw Options [continued]

AcuTwist® Acutrak® Compression Screw

The AcuTwist Acutrak Compression Screw is designed to provide compressive fixation for use in fractures, fusions, and osteotomies. It is not intended for interference or soft tissue fixation.

The screw design includes a variable thread pitch, a tapered profile, a break-off groove, and threads along the entire length of the screw. The fully threaded screw length allows for greater resistance to pull-out force than partially threaded headed and headless screws.⁴

Visit www.acumed.net for the AcuTwist Acutrak Compression Screw surgical technique (SPF00-07).



Acumed Tension Band Pin System

The Acumed Tension Band Pin System is the first interlocking solution designed to provide low-profile, secure fixation for patella, olecranon, and malleolus fractures to minimize soft tissue irritation and postoperative pin migration. This innovative solution is intended to minimize post-surgical complications associated with traditional tension band pinning with K-wires.

An eyelet is located on the proximal end of the stainless steel pin. The pin is secured by passing the cerclage wire through the eyelet, minimizing migration of the pins postoperatively. The capturing of the pin allows compression to be maintained across the fracture or osteotomy site.

Visit www.acumed.net for the Tension Band Pin System surgical technique (SPF00-04).



Acumed Variable Angle Screw Features



The 2.7 mm and 3.5 mm Variable Angle Screws are included as part of the Small Fragment Base Set. These screws can be used in locking plate holes within the Small Fragment Base Set plates as well as any systems dependent upon the Small Fragment Base Set. The variable angle hexalobe screw has a spherical head to accommodate insertion at various angles and may be angled up to 15 degrees off axis in any direction. Variable angle screws are provided to aid in the capture of specific fragments and to accommodate variations in patient anatomy.

Variable angle screws are designed to facilitate screw placement and allow the surgeon to:

- ▶ Target and capture best quality bone
- ▶ Angle screw to avoid joint penetration
- ▶ Tailor screw position to accommodate differences in patient anatomy and fracture fragment location
- ▶ Avoid existing implants

Acumed Variable Angle Screw Features [continued]

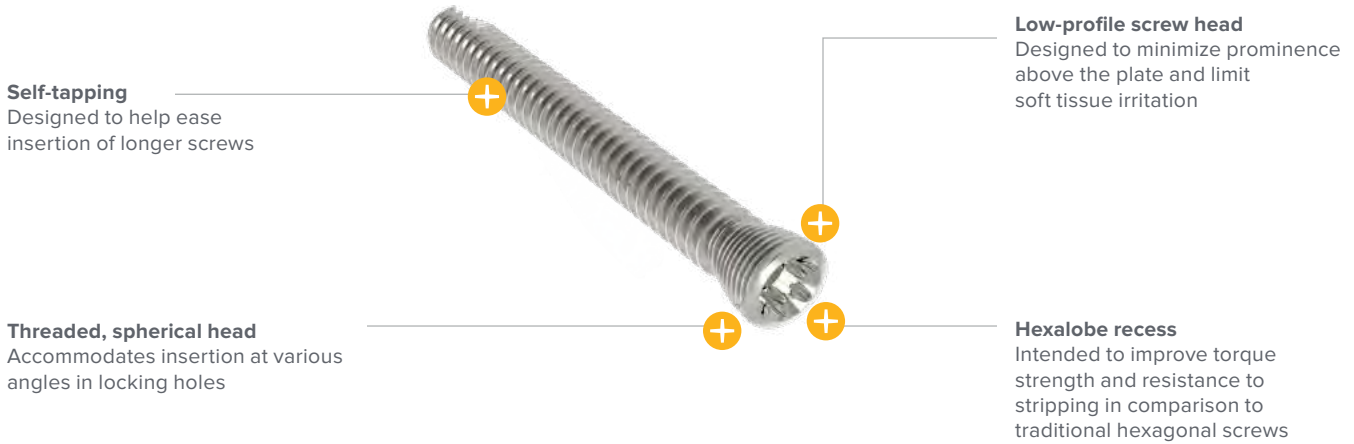

Acumed Variable Angle Screw Features [continued]

Locking up to 15 degrees off axis in any direction
Designed to allow for targeting of screw to avoid other implants, accommodation of varying patient anatomies, and positioning of screw to avoid joint spaces and capture best quality bone



Surgical Technique Overview

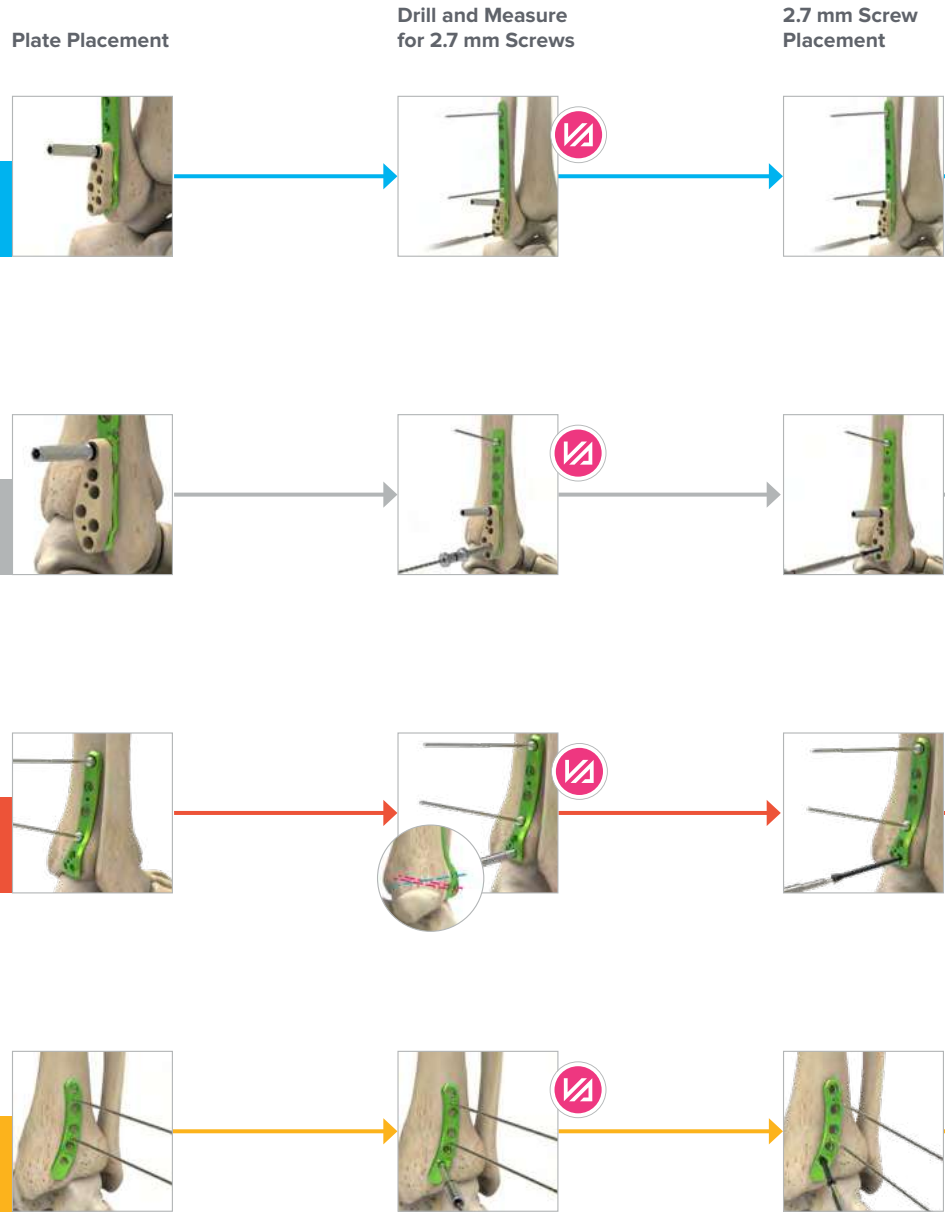

Drill and Measure
for 3.5 mm Screws

3.5 mm Screw
Placement

Optional
Syndesmosis Repair

Confirmation

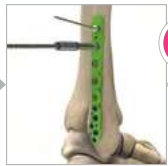
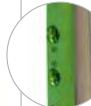
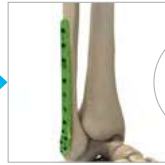
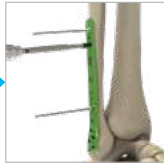

Surgical Technique Overview [continued]

Medial Anti-Glide Plate

Plate Placement



Drill and Measure for 2.7 mm Screws

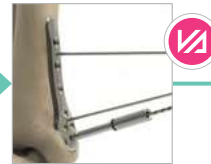

2.7 mm Screw Placement



Hook Plate



2.3 mm Peg Placement

Locking Peg Hook Plate



Variable Angle Screw Surgical Technique

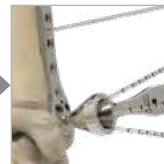

4.0 mm Cannulated Screw

Guide Wire Placement

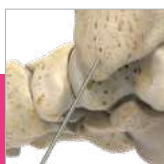

Measure for 4.0 mm Cannulated Screw



Drill and Measure for 3.5 mm Screws



3.5 mm Screw Placement



Confirmation



Drill for 4.0 mm Cannulated Screw



4.0 mm Cannulated Screw Placement

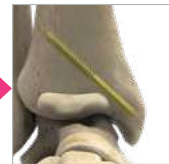

Lateral Fibula Plate Surgical Technique

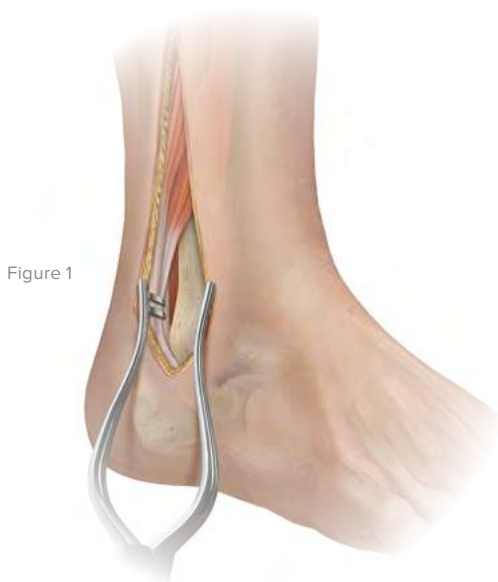

Figure 1

Note: The Acumed Small Fragment Base Set houses the screws and standard instrumentation needed for this procedure and must be used in conjunction with the Acumed Ankle Plating System 3.

1 Patient Positioning and Exposure

Position the patient supine and make a straight lateral or posterolateral surgical incision to expose the fracture of the fibula. After attaining appropriate exposure, care should be taken with vital soft tissue structures.

2 Fracture Reduction

Reduce the fracture using manual techniques. Provisional stability can be achieved utilizing forceps or .062" x 6" Guide Wires (WS-1607ST) and can be evaluated under fluoroscopy. Accurate restoration of fibular length, alignment, and rotation is critical.

Caution: Optional Lateral Fibula Targeting Blocks (80-2310 and 80-2311) are provided to aid in the installation of 2.7 mm Locking Hexalobe Screws (30-XXXX). If a Targeting Block will be used, it should be attached to the plate before placement of the plate on the bone. Instructions for attachment of the Targeting Block are included in Step 4 of this technique.

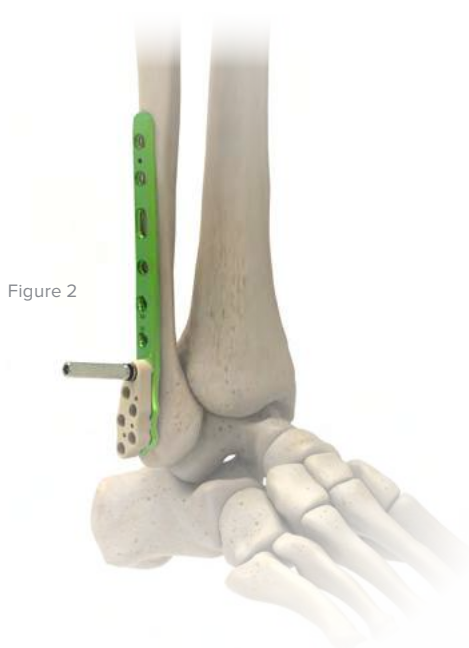

Figure 2

3 Plate Placement

Position the Lateral Fibula Plate (7007-010XX) appropriately and fix provisionally with .062" x 6" Guide Wires or .062" x 3" Threaded Plate Tacks (80-2430). Evaluation under fluoroscopy can help confirm satisfactory placement of the plate.



.062" x 6"
Guide Wire
(WS-1607ST)



Lateral Fibula
Targeting Blocks
(80-2310 and
80-2311)



2.7 mm Locking
Hexalobe Screws
8–60 mm lengths
(30-XXXX)



Lateral Fibula
Plate
(7007-010XX)



.062" x 3"
Threaded
Plate Tack
(80-2430)

Lateral Fibula Plate Surgical Technique [continued]

4 Distal 2.7 mm Hexalobe Screw Placement

All distal plate holes can accept 2.7 mm hexalobe screws.

To insert 2.7 mm **Nonlocking** Hexalobe Screws (30-XXXX) into the distal cluster of holes, drill with the 2.0 mm Quick Release Drill w/ Depth Marks (80-2378) through the 2.0 mm/2.7 mm Drill Guide (80-2516) to the desired depth. If one of the Lateral Fibula Targeting Blocks (80-2310 and 80-2311) is attached, the 2.0 mm Drill Guide (80-2314) must be used. Measure for screw length by using the Depth Gauge (80-2496).

To insert 2.7 mm **Locking** Hexalobe Screws (30-XXXX), there are two drill guides available for use.

Option One: Attach either the Lateral Fibula Targeting Block Left (80-2310) or the Lateral Fibula Targeting Block Right (80-2311) to the plate by threading the Targeting Block Locking Bolt (80-2315) through the most proximal hole of the Lateral Fibula Targeting Block. Insert the 2.0 mm Drill Guide through the targeting block and into the desired hole.

Option Two: Thread the 2.0 mm Locking Drill Guide (80-2371) into each hole.

Once the Lateral Fibula Targeting Block or 2.0 mm Locking Drill Guide is attached, drill using the 2.0 mm Quick Release Drill to the desired depth. Measure for screw length by referencing the laser mark on the drill where it meets the back end of the drill guide (Figure 3). Alternatively, detach the Locking Drill Guide and use the Depth Gauge (80-2496) to measure for screw length (Figure 4).

Insert 2.7 mm Locking or Nonlocking Hexalobe Screws by connecting the T8 Stick Fit Hexalobe Driver (80-0759) to the Cannulated Quick Release Driver Handle, Medium (80-2364).

Caution: Care must be taken to avoid over tightening during the final seating of the 2.7mm **Locking** Hexalobe Screws into the Lateral Fibula Plate (7007-01XXX). A two finger tightening technique is recommended for use with the Cannulated Quick Release Handle, **Medium** (80-2364) to seat the 2.7mm Locking Hexalobe Screws into the plate.

Caution: Use the maximum number of screws based on the indication to reduce the risk of screw breakage during healing.

Note: Optional 2.7 mm Variable Angle Hexalobe Screws (3013-27XXX) are available. See technique on page 42.

Confirm screw placement under fluoroscopy.



Figure 3



Figure 4

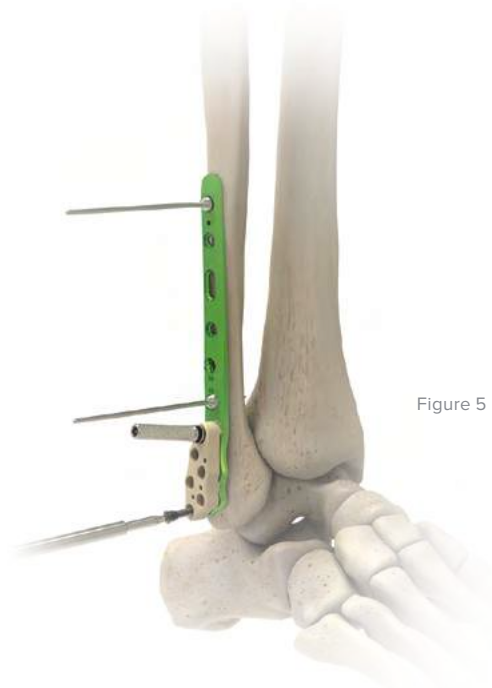

Figure 5



2.7 mm Nonlocking Hexalobe Screws, 8–60 mm lengths (30-XXXX)



2.0 mm Quick Release Drill w/ Depth Marks (80-2378)



2.0 mm/2.7 mm Drill Guide (80-2516)



Lateral Fibula Targeting Blocks (80-2310 and 80-2311)



2.0 mm Drill Guide (80-2314)



Depth Gauge (80-2496)



2.7 mm Locking Hexalobe Screws, 8–60 mm lengths (30-XXXX)



Targeting Block Locking Bolt (80-2315)

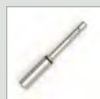

2.0 mm Locking Drill Guide (80-2371)



T8 Stick Fit Hexalobe Driver (80-0759)



Cannulated Quick Release Driver Handle, Medium (80-2364)



2.7 mm Variable Angle Hexalobe Screw 10–60 mm lengths (3013-27XXX)

Lateral Fibula Plate Surgical Technique [continued]

Figure 6



5 Proximal 3.5 mm Hexalobe Screw Placement

The proximal plate holes can accept 3.5 mm hexalobe screws.

If a syndesmosis repair will be performed, the desired hole(s) marked with an “S” must be left open. The distal hole is designed to target syndesmosis fixation at approximately 1 centimeter above the tibial plafond, while the proximal hole is designed to target 2 centimeters above the tibial plafond. These syndesmotomic screw holes, marked with an “S,” do not accept variable angle screws.

To insert 3.5 mm **Nonlocking** Hexalobe Screws (30-XXXX), drill with the 2.8 mm Quick Release Drill w/ Depth Marks (80-2379) through the 2.8 mm/3.5 mm Drill Guide (80-2517) to the desired depth (Figure 6). Measure for screw length by using the Depth Gauge (80-2496).

To insert 3.5 mm **Locking** Hexalobe Screws (30-XXXX), thread the 2.8 mm Locking Drill Guide (80-2372) into the proximal plate holes. Drill through the 2.8 mm Locking Drill Guide with the 2.8 mm Quick Release Drill w/ Depth Marks to the desired depth (Figure 7). Measure for screw length by referencing the laser mark on the drill where it meets the back end of the 2.8 mm Locking Drill Guide. Alternatively, detach the 2.8 mm Locking Drill Guide and use the Depth Gauge to measure for screw length.

Figure 7



Insert 3.5 mm Locking or Nonlocking Hexalobe Screws by connecting the T15 Stick Fit Hexalobe Driver (80-0760) to the Cannulated Quick Release Driver Handle, Large (80-2365).

Caution: Use the maximum number of screws based on the indication to reduce the risk of screw breakage during healing.

Note: Optional 4.0 mm Fully Threaded Cancellous Hexalobe Screws (3015-400XX) are available and can be used in place of 3.5 mm Hexalobe Screws.

Note: Optional 3.5 mm Variable Angle Hexalobe Screws (3013-35XXX) are available. See technique on page 42.

Confirm screw placement under fluoroscopy.

Figure 8



Lateral Fibula Plate Surgical Technique [continued]

6 Optional Syndesmosis Repair

If the syndesmosis requires stabilization, a 3.5 mm **Locking Hexalobe Screws**, 8–65 mm lengths (30-XXXX) or **Nonlocking Hexalobe Screws**, 8–65 mm lengths (30-XXXX) can be utilized for fixation.

Each Lateral Fibula Plate contains two holes labeled with an “S” for syndesmosis (Figure 9). These holes are angled 30° anterior to target the center of the tibia. The 2.8 mm Locking Drill Guide (80-2372) must be used in order to attain this targeted trajectory. The plate holes labeled with an “S” can accept either Locking or Nonlocking 3.5 mm Hexalobe Screws.

Thread the 2.8 mm Locking Drill Guide into one of the “S” screw holes and drill to the appropriate depth using the 2.8 mm Quick Release Drill, w/ Depth Marks (80-2379) (Figure 10A). Measure for screw length by referencing the laser mark on the drill where it meets the back end of the Locking Drill Guide. Alternatively, detach the Locking Drill Guide and use the Depth Gauge (80-2496) to measure for screw length. Remove the 2.8 mm Locking Drill Guide and insert the appropriate length 3.5 mm Locking or Nonlocking Hexalobe Screws by connecting the T15 Stick Fit Hexalobe Driver (80-0760) to the Cannulated Quick Release Driver Handle, Large (80-2365).

Confirm screw placement under fluoroscopy.

Closing and postoperative protocol are at the discretion of the surgeon.

Warning: Screws placed across the syndesmosis have a higher probability of failure due to the higher stresses associated with this area. Particular postoperative precautions are advised in this application.



Figure 9

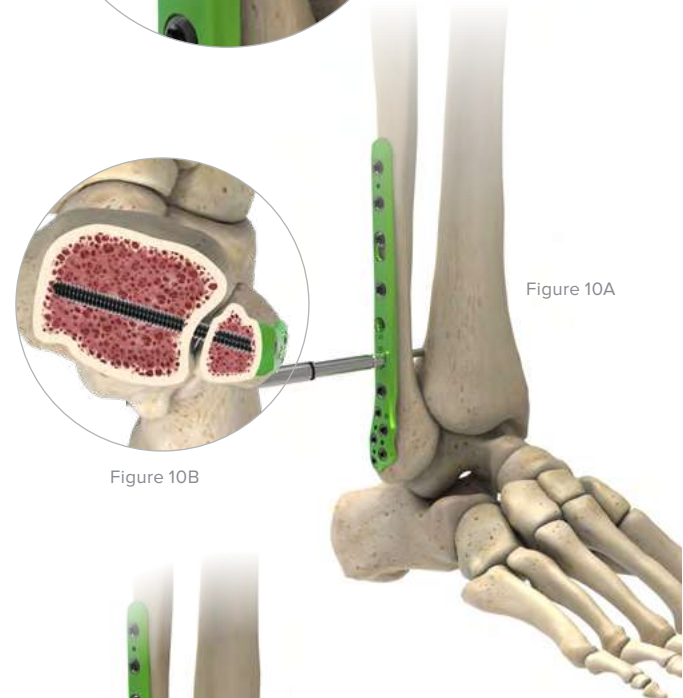

Figure 10A



Figure 10B



Figure 11



3.5 mm Locking Hexalobe Screws, 8–65 mm lengths (30-XXXX)



3.5 mm Nonlocking Hexalobe Screws, 8–65 mm length (30-XXXX)



2.8 mm Locking Drill Guide (80-2372)

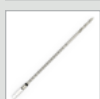

2.8 mm Quick Release Drill, w/ Depth Marks (80-2379)



Depth Gauge (80-2496)



T15 Stick Fit Hexalobe Drive (80-0760)



Cannulated Quick Release Driver Handle, Large (80-2365)

Posterolateral Fibula Plate Surgical Technique

Figure 12



Note: The Acumed Small Fragment Base Set houses the screws and standard instrumentation needed for this procedure and must be used in conjunction with the Acumed Ankle Plating System 3.

1 Patient Positioning and Exposure

Position the patient supine and make a straight lateral or posterolateral surgical incision to expose the fracture of the fibula.

Alternative positioning: Prone patient position may be preferred if prioritizing a posterior tibia fracture. Position the patient prone and make a posterolateral surgical incision.

After attaining appropriate position and exposure, care should be taken with vital soft tissue structures.

2 Fracture Reduction

Reduce the fracture using manual techniques. Provisional stability can be achieved utilizing forceps or .062" x 6" Guide Wires (WS-1607ST) and can be evaluated under fluoroscopy. Accurate restoration of fibular length, alignment, and rotation is critical.

Caution: Optional Posterolateral Fibula Targeting Blocks (80-2312 and 80-2313) are provided to aid in the installation of 2.7 mm **Locking** Hexalobe Screws, (30-XXXX). If a Targeting Block will be used, it should be attached to the plate before placement of the plate on the bone. Instructions for attachment of the Targeting Block are included in Step 4 of this technique.

3 Plate Placement

Position the Posterolateral Fibula Plate (7007-02XXX) appropriately, with the distal end placed in the posterolateral groove of the distal fibula. Provisionally fix the plate to the bone with .062" x 6" Guide Wires or .062" x 3" Threaded Plate Tacks (80-2430). Evaluation under fluoroscopy can confirm satisfactory placement of the plate.

Note: The 2.8 mm Locking Drill Guide (80-2372) can be attached to the plate to act as a handle and aid in provisional plate placement.

Figure 13



.062" x 6"
Guide Wire
(WS-1607ST)



Posterolateral Fibula
Targeting Blocks
(80-2312 or 80-2313)



2.7 mm Locking
Hexalobe Screws,
8–65 mm lengths
(30-XXXX)



Posterolateral
Fibula Plate
(7007-02XXX)



.062" x 3"
Threaded
Plate Tack
(80-2430)



2.8 mm Locking
Drill Guide
(80-2372)

Posterolateral Fibula Plate Surgical Technique [continued]

4 Distal 2.7 mm Hexalobe Screw Placement

All distal plate holes can accept 2.7 mm hexalobe screws.

To insert 2.7 mm **Nonlocking** Hexalobe Screws (30-XXXX) into the distal cluster of holes, drill with the 2.0 mm Quick Release Drill w/ Depth Marks (80-2378) through the 2.0 mm/2.7 mm Drill Guide (80-2516) to the desired depth. Measure for screw length by using the Depth Gauge (80-2496).

To insert 2.7 mm **Locking** Hexalobe Screws (30-XXXX), there are two drill guides available for use.

Option One: Attach either the Posterolateral Fibula Targeting Block Left (80-2312) or the Posterolateral Fibula Targeting Block Right (80-2313) to the plate by threading the Targeting Block Locking Bolt (80-2315) through the most proximal hole of the Posterolateral Fibula Targeting Block. Insert the 2.0 mm Drill Guide (80-2314) through the targeting block and into the desired hole.

Option Two: Thread the 2.0 mm Locking Drill Guide (80-2371) into each hole.

Once the Posterolateral Fibula Targeting Block or 2.0 mm Locking Drill Guide is attached, drill using the 2.0 mm Quick Release Drill (Figure 16). Measure for screw length by referencing the laser mark on the drill where it meets the back end of the Locking Drill Guide (Figure 14). Alternatively, detach the Locking Drill Guide and use the Depth Gauge to measure for screw length (Figure 15).

Insert 2.7 mm Locking or Nonlocking Hexalobe Screws by connecting the T8 Stick Fit Hexalobe Driver (80-0759) to the Cannulated Quick Release Driver Handle, Medium (80-2364).

Caution: Care must be taken to avoid over tightening during the final seating of the 2.7 mm **Locking** Hexalobe Screws into the Posterolateral Fibula Plate (7007-02XXX). A two finger tightening technique is recommended for use with the Cannulated Quick Release Handle, **Medium** (80-2364) to seat the 2.7mm Locking Hexalobe Screws into the plate.

Caution: Use the maximum number of screws based on the indication to reduce the risk of screw breakage during healing.

Note: Optional 2.7 mm Variable Angle Hexalobe Screws (3013-27XXX) are available. See technique on page 42.

Confirm screw placement under fluoroscopy.



Figure 14



Figure 15

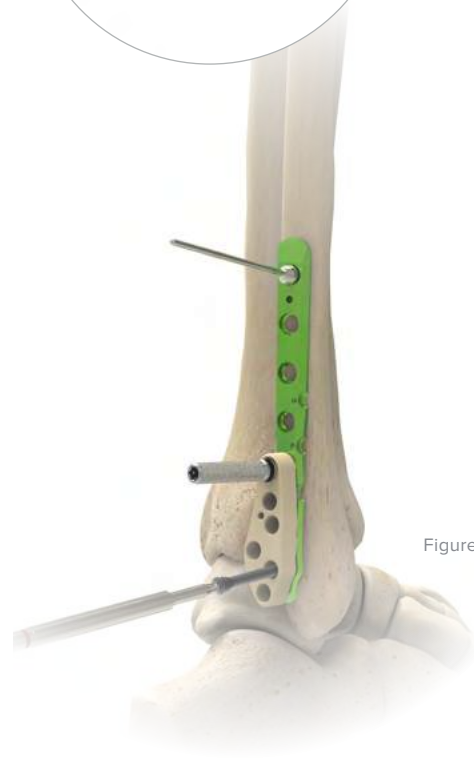

Figure 16



Posterolateral Fibula Plate Surgical Technique [continued]

Figure 17

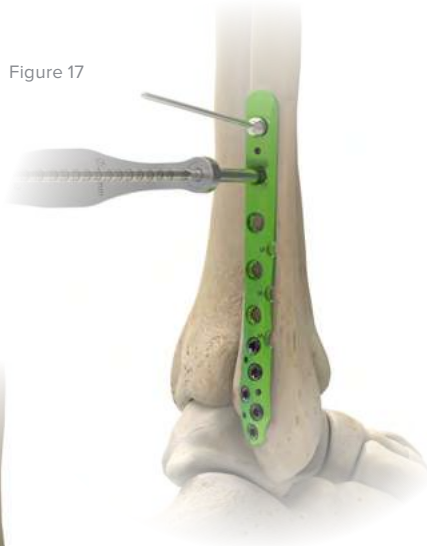

Figure 18

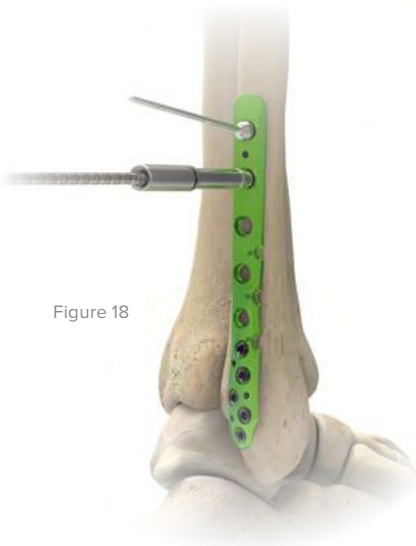

Figure 19



5 Proximal 3.5 mm Hexalobe Screw Placement

All proximal plate holes can accept 3.5 mm hexalobe screws.

Prior to inserting screws in the proximal portion of the plate, note that there are three scallops on the plate marked with an “S” that indicate screw locations targeted by the Syndesmosis Targeting Guide Assembly (80-2325), as shown in Step 6. If planning to repair the syndesmosis, one of the plate holes between the scallops must be left open. The distal hole is designed to target syndesmosis fixation at approximately 1 to 2 centimeters above the tibial plafond, while the proximal hole is designed to target 2 to 3 centimeters above the tibial plafond. The plate scallops accommodate placement of the targeted 3.5 mm nonlocking hexalobe screw adjacent to the plate.

To insert 3.5 mm **Nonlocking** Hexalobe Screws (30-XXXX), drill with the 2.8 mm Quick Release Drill, w/ Depth Marks (80-2379) through the 2.8 mm/3.5 mm Drill Guide (80-2517) to the desired depth (Figure 17). Measure for screw length by using the Depth Gauge (80-2496).

To insert 3.5 mm **Locking** Hexalobe Screws (30-OXXX), thread the 2.8 mm Locking Drill Guide (80-2372) into the proximal plate holes. Drill through the 2.8 mm Locking Drill Guide with the 2.8 mm Quick Release Drill to the desired depth (Figure 18). Measure for screw length by referencing the laser mark on the drill where it meets the back end of the locking drill guide. Alternatively, detach the locking drill guide and use the depth gauge to measure for screw length.

Insert 3.5 mm Locking and Nonlocking Hexalobe Screws by connecting the T15 Stick Fit Hexalobe Driver (80-0760) to the Cannulated Quick Release Driver Handle, Large (80-2365).

Caution: Use the maximum number of screws based on the indication to reduce the risk of screw breakage during healing.

Note: Optional 4.0 mm Fully Threaded Cancellous Hexalobe Screws (3015-400XX) are available and can be used in place of 3.5 mm hexalobe screws.

Note: Optional 3.5 mm Variable Angle Hexalobe Screws (3013-35XXX) are available. See technique on page 42.

Confirm screw placement under fluoroscopy.



Posterolateral Fibula Plate Surgical Technique [continued]

6 Optional Syndesmosis Repair

If the syndesmosis requires stabilization, a 3.5 mm Non-locking Hexalobe Screw (30-XXXX) can be utilized for fixation.

Attach the Syndesmosis Targeting Guide Assembly (80-2325) in either of the two plate holes between the scallops marked with an “S” (Figure 20). Attaching the guide to the distal hole will target syndesmosis fixation at either 1 or 2 centimeters above the tibial plafond, while the proximal hole will target fixation at 2 or 3 centimeters above the tibial plafond.

Note: If a screw has previously been installed in the desired plate hole, it must be temporarily removed in order to attach the Syndesmosis Targeting Guide.

The Syndesmosis Targeting Guide maintains a fixed entry point in the fibula, adjacent to the posterolateral fibula plate, while allowing for adjustment in the screw angle. This enables the user to target the desired exit point across varying patient anatomies (Figure 22B).

Once the Syndesmosis Targeting Guide is attached to the plate, adjust the slider to the desired trajectory and lock the adjustment knob into place. Install a .062" x 6" Guide Wire (WS-1607ST) through the center hole in the Syndesmosis Targeting Guide. If desired, the guide wire can be driven through the medial cortex of the tibia to demonstrate the trajectory of the syndesmosis fixation.

Remove the .062" x 6" Guide Wire and adjust the trajectory if necessary until the desired screw positioning is reached. Drill through the Syndesmosis Targeting Guide with the 2.8 mm Quick Release Drill, w/ Depth Marks (80-2379) to the desired depth (Figure 22A).

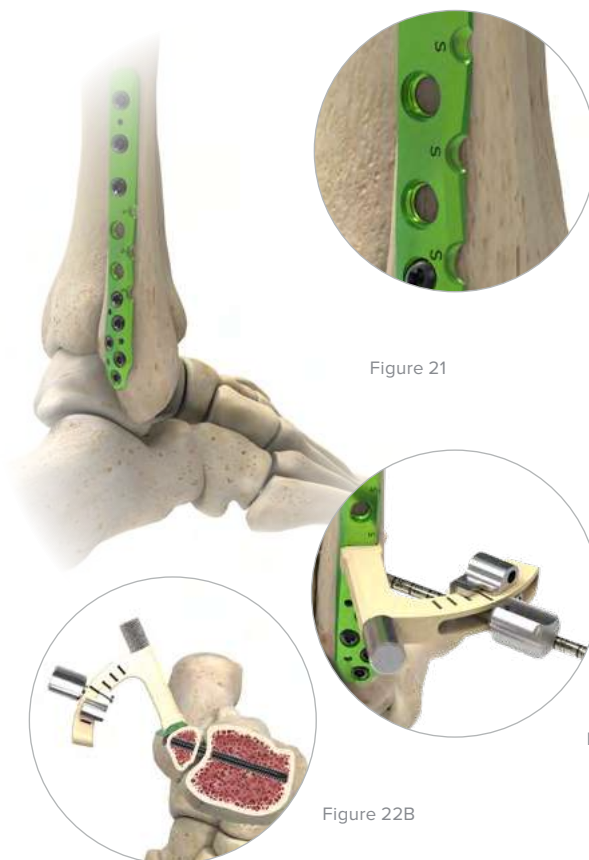

Figure 20

Figure 21

Figure 22A

Figure 22B



3.5 mm Non-locking Hexalobe Screw, 8–65 mm lengths (30-XXXX)



Syndesmosis Targeting Guide Assembly (80-2325)



.062" x 6" Guide Wire (WS-1607ST)



2.8 mm Quick Release Drill, w/ Depth Marks (80-2379)

Posterolateral Fibula Plate Surgical Technique [continued]



Figure 23



Figure 24

Note: Additional holes may be drilled using the Syndesmosis Targeting Guide if more than one screw is desired for syndesmosis fixation.

Remove the Syndesmosis Targeting Guide, measure screw length using the Depth Gauge (80-2496) and insert the proper length 3.5 mm **Nonlocking** Hexalobe Screw (30-XXXX) by connecting the T15 Stick Fit Hexalobe Driver (80-0760) to the Cannulated Quick Release Driver Handle, Large (80-2365).

Confirm screw placement under fluoroscopy.

Closing and postoperative protocol are at the discretion of the surgeon.

Warning: Screws placed across the syndesmosis have a higher probability of failure due to the higher stresses associated with this area. Particular postoperative precautions are advised in this application.



Depth Gauge
(80-2496)



3.5 mm Nonlocking
Hexalobe Screws,
8–65 mm lengths
(30-XXXX)



T15 Stick
Fit Hexalobe
Driver
(80-0760)



Cannulated
Quick Release
Driver Handle,
Large
(80-2365)

Posterolateral Distal Tibia Plate Surgical Technique

Note: The Acumed Small Fragment Base System houses the screws and standard instrumentation needed for this procedure and must be used in conjunction with an Ankle Plating System 3 tray for this case.

1 Patient Positioning and Exposure

Position the patient prone to expose the surgical site and make a posterolateral surgical incision to expose the fracture of the tibia.

Alternative Positioning

Position the patient supine and make a posterolateral surgical incision to expose the fracture of the tibia.

Note: Placing the patient in the supine position may inhibit the ability to reduce the fracture, given the difficulty in visualizing the posterolateral tibia.

Retract the Achilles tendon medially to expose the flexor hallucis longus (FHL) tendon. The FHL tendon should be elevated from the posterior tibia and retracted medially. Proximal dissection is taken with caution to avoid damage to the peroneal artery.

After attaining appropriate position and exposure, care should be taken with vital soft tissue structures.



Figure 25

2 Fracture Reduction

Reduce the fracture using manual techniques. Provisional stability can be achieved utilizing forceps or .062" x 6" Guide Wires (WS-1607ST) and can be evaluated under fluoroscopy.

3 Plate Placement

Position the Posterolateral Distal Tibia Plate (7007-03XXX) appropriately and fix provisionally with .062" x 6" Guide Wires (WS-1607ST) or .062" x 3" Threaded Plate Tacks (80-2430). Evaluation under fluoroscopy can confirm satisfactory placement of the plate.

Note: The 2.8 mm Locking Drill Guide (80-2372) can be attached to the plate to act as a handle and aid in provisional plate placement.

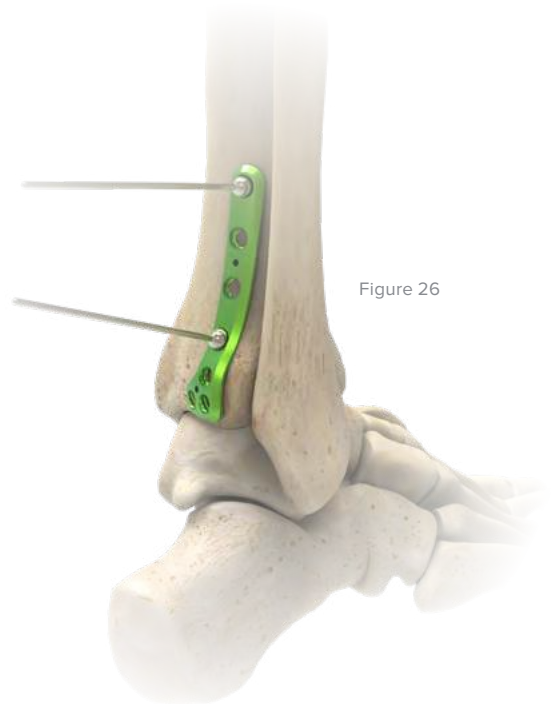

Figure 26



.062" x 6"
Guide Wire
(WS-1607ST)



Posterolateral
Distal Tibia Plate
(7007-03XXX)



.062" x 3"
Threaded
Plate Tack
(80-2430)



2.8 mm Locking
Drill Guide
(80-2372)

Posterolateral Distal Tibia Plate Surgical Technique [continued]

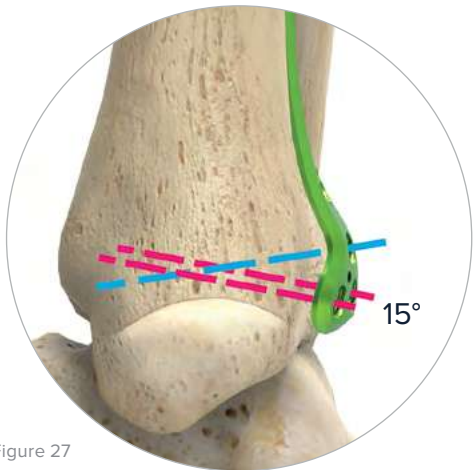

Figure 27

4 Distal 2.7 mm Hexalobe Screw Placement

The distal screw hole trajectories are angled approximately 15 degrees superiorly, with the intention to avoid the joint space (Figure 27). In order to attain these trajectories, the 2.0 mm Locking Drill Guide (80-2371) must be used. All distal plate holes can accept 2.7 mm hexalobe screws.

To insert 2.7 mm **Nonlocking** Hexalobe Screws (30-XXXX), thread the 2.0 mm Locking Drill Guide into the desired hole. Using the 2.0 mm Locking Drill Guide will help ensure that the drill and screw do not hit the joint space. Drill through the 2.0 mm Locking Drill Guide with the 2.0 mm Quick Release Drill w/ Depth Marks (80-2378) to the desired depth. Measure for screw length by referencing the laser mark on the drill where it meets the back end of the locking drill guide. Alternatively, detach the locking drill guide and use the Depth Gauge (80-2496) to measure for screw length.

To insert 2.7 mm **Locking** Hexalobe Screws (30-XXXX), thread the 2.0 mm Locking Drill Guide into the desired hole. Drill through the 2.0 mm Locking Drill Guide with the 2.0 mm Quick Release Drill to the desired depth. Measure for screw length by referencing the laser mark on the drill where it meets the back end of the locking drill guide. Alternatively, detach the locking drill guide and use the depth gauge to measure for screw length.

Insert 2.7 mm Locking and Nonlocking Hexalobe Screws by connecting the T8 Stick Fit Hexalobe Driver (80-0759) to the Cannulated Quick Release Driver Handle, Medium (80-2364).

Caution: Use the maximum number of screws based on the indication to reduce the risk of screw breakage during healing.

Note: Optional 2.7 mm Locking Variable Angle Hexalobe Screws (3013-27XXX) are available. See technique on page 42.

Confirm screw placement under fluoroscopy.

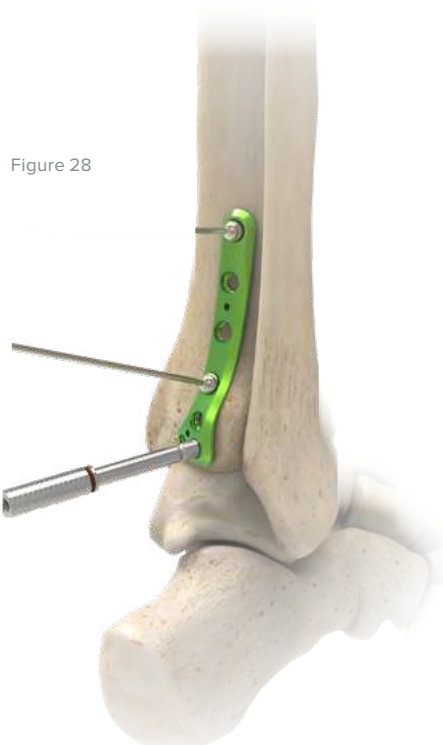

Figure 28

- | | | | |
|--|--|--|--|
| | | | |
| | | | |

Posterolateral Distal Tibia Plate Surgical Technique [continued]

5 Proximal 3.5 mm Hexalobe Screw Placement

All proximal plate holes can accept 3.5 mm Hexalobe Screws.

To insert 3.5 mm **Nonlocking** Hexalobe Screws (30-XXXX), drill with the 2.8 mm Quick Release Drill, w/ Depth Marks (80-2379) through the 2.8 mm/3.5 mm Drill Guide (80-2517) to the desired depth (Figure 29). Measure for screw length by using the Depth Gauge (80-2496).

To insert 3.5 mm **Locking** Hexalobe Screws (30-XXXX), thread the 2.8 mm Locking Drill Guide (80-2372) into the desired hole. Drill through the 2.8 mm Locking Drill Guide with the 2.8 mm Quick Release Drill to the desired depth (Figure 30). Measure for screw length by referencing the laser mark on the drill where it meets the back end of the locking drill guide. Alternatively, detach the locking drill guide and use the depth gauge to measure for screw length.

Insert 3.5 mm Locking and Nonlocking Hexalobe Screws by connecting the T15 Stick Fit Hexalobe Driver (80-0760) to the Cannulated Quick Release Driver Handle, Large (80-2365).

Caution: Use the maximum number of screws based on the indication to reduce the risk of screw breakage during healing.

Note: Optional 4.0 mm Fully Threaded Cancellous Hexalobe Screws (3015-400XX) are available and can be used in place of 3.5 mm hexalobe screws.

Note: Optional 3.5 mm Locking Variable Angle Hexalobe Screws (3013-35XXX) are available. See technique on page 42.

Confirm screw placement under fluoroscopy.

Closing and postoperative protocol are at the discretion of the surgeon.



Figure 29



Figure 30

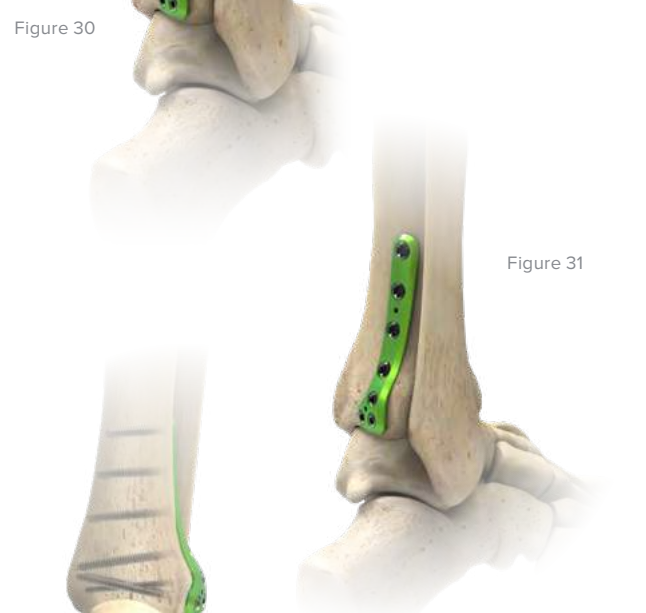

Figure 31

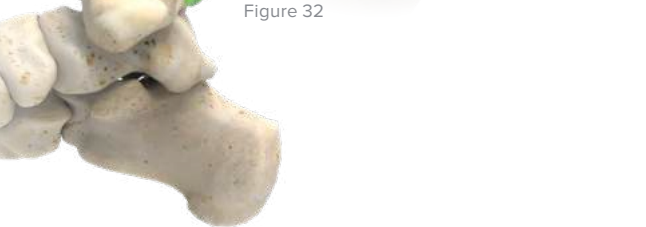





Figure 32

	3.5 mm Nonlocking Hexalobe Screws, 8–65 mm lengths (30-XXXX)		2.8 mm Quick Release Drill, w/ Depth Marks (80-2379)		2.8 mm/3.5 mm Drill Guide (80-2517)		Depth Gauge (80-2496)		3.5 mm Locking Hexalobe Screws, 8–65 mm lengths (30-XXXX)
	2.8 mm Locking Drill Guide (80-2372)		T15 Stick Fit Hexalobe Driver (80-0760)		Cannulated Quick Release Driver Handle, Large (80-2365)		4.0 mm Fully Threaded Cancellous Hexalobe Screws, 10–60 mm lengths (3015-400XX)		3.5 mm Variable Angle Hexalobe Screws, 10–60 mm lengths (3013-35XXX)

Posteromedial Distal Tibia Plate Surgical Technique

Figure 33



Figure 34

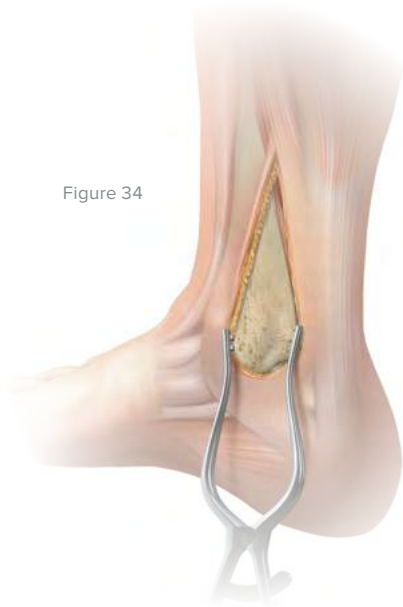

Note: The Acumed Small Fragment Base System houses the screws and standard instrumentation needed for this procedure and must be used in conjunction with the Acumed Ankle Plating System 3.

1 Patient Positioning Options

Prone Patient Positioning and Exposure

Position the patient prone to expose the surgical site. A posteromedial incision, based at the interval between the posteromedial tibia and posterior tibial tendon, can be utilized to provide exposure to the posterior tibia. The posterior tibial tendon is identified and retracted laterally, to expose the fracture and allow for plate placement.

Alternative Prone Incision

A posterolateral incision based off the lateral border of the Achilles tendon can provide exposure to the entire posterior tibia and fibula. The posterior tibial tendon is identified and retracted medially to expose the fracture and allow plate placement.

Alternative Positioning

Position the patient supine. Make a medial or posteromedial surgical incision to expose the fracture of the tibia. The posterior tibial tendon is retracted laterally to expose the fracture and allow placement of the plate.

Note: Placing the patient in the supine position may complicate the ability to reduce the fracture.

After attaining appropriate position and exposure, care should be taken with vital soft tissue structures.

2 Fracture Reduction

Reduce the fracture using manual techniques. Provisional stability can be achieved utilizing forceps or .062" x 6" Guide Wires (WS-1607ST) and can be evaluated under fluoroscopy.



.062" x 6"
Guide Wire
(WS-1607ST)

Posteromedial Distal Tibia Plate Surgical Technique [continued]

3 Plate Placement

The Posteromedial Distal Tibia Plate (7007-04XXX) has been designed to fit into the posterior tibial tendon groove for fixation of the posteromedial tibial fragment. Position the plate appropriately and fix provisionally with .062" x 6" Guide Wires (WS-16075T) or .062" x 3" Threaded Plate Tacks (80-2430). Evaluation under fluoroscopy can confirm satisfactory placement of the plate.

Note: The 2.8 mm Locking Drill Guide (80-2372) can be attached to the plate to act as a handle and aid in provisional plate placement.

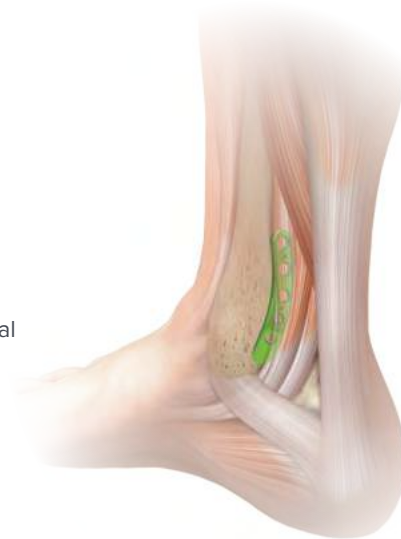

Figure 35

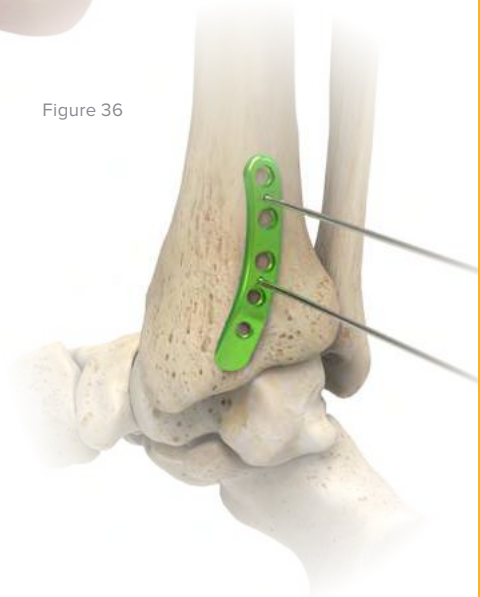

Figure 36



Posteromedial
Distal Tibia Plate
(7007-04XXX)



.062" x 6"
Guide Wire
(WS-1607ST)



.062" x 3"
Threaded
Plate Tack
(80-2430)



2.8 mm Locking
Drill Guide
(80-2372)

Posteromedial Distal Tibia Plate Surgical Technique [continued]



Figure 37

4 Distal 2.7 mm Hexalobe Screw Placement

The distal screw hole trajectories are angled with the intention to avoid the joint space. The two most distal plate holes can accept 2.7 mm Hexalobe Screws.

To insert 2.7 mm **Nonlocking** Hexalobe Screws (30-XXXX), drill with the 2.0 mm Quick Release Drill w/ Depth Marks (80-2378) through the 2.0 mm/2.7 mm Drill Guide (80-2516) or the 2.0 mm Locking Drill Guide (80-2371) to the desired depth. Measure for screw length by using the Depth Gauge (80-2496).

To insert 2.7 mm **Locking** Hexalobe Screws (30-XXXX), thread the 2.0 mm Locking Drill Guide into the desired hole. Drill through the 2.0 mm Locking Drill Guide with the 2.0 mm Quick Release Drill w/ Depth Marks to the desired depth. Measure for screw length by referencing the laser mark on the drill where it meets the back end of the locking drill guide. Alternatively, detach the locking drill guide and use the Depth Gauge to measure for screw length.

Insert 2.7 mm Locking or Nonlocking Hexalobe Screws by connecting the T8 Stick Fit Hexalobe Driver (80-0759) to the Cannulated Quick Release Driver Handle, Medium (80-2364).

Caution: Use the maximum number of screws based on the indication to reduce the risk of screw breakage during healing.

Note: Optional 2.7 mm Locking Variable Angle Hexalobe Screws (3013-35XX) are available. See technique on page 42.

Confirm screw placement under fluoroscopy.



2.7 mm Nonlocking Hexalobe Screws, 8–60 mm lengths (30-XXXX)



2.0 mm Quick Release Drill w/ Depth Marks (80-2378)



2.0 mm/2.7 mm Drill Guide (80-2516)



2.0 mm Locking Drill Guide (80-2371)



Depth Gauge (80-2496)



2.7 mm Locking Hexalobe Screws, 8–60 mm lengths (30-XXXX)



T8 Stick Fit Hexalobe Driver (80-0759)



Cannulated Quick Release Driver Handle, Medium (80-2364)



2.7 mm Locking Variable Angle Hexalobe Screws, 10–60 mm lengths (3013-35XX)

Posteromedial Distal Tibia Plate Surgical Technique [continued]

5 Proximal 3.5 mm Hexalobe Screw Placement

All proximal plate holes can accept 3.5 mm Hexalobe Screws.

To insert 3.5 mm **Nonlocking** Hexalobe Screws (30-XXXX), drill with the 2.8 mm Quick Release Drill, w/ Depth Marks (80-2379) through the 2.8 mm/3.5 mm Drill Guide (80-2517) to the desired depth (Figure 38). Measure for screw length by using the Depth Gauge (80-2496).

To insert 3.5 mm **Locking** Hexalobe Screws (30-XXXX), thread the 2.8 mm Locking Drill Guide (80-2372) into each plate hole. Drill through the 2.8 mm Locking Drill Guide with the 2.8 mm Quick Release Drill to the desired depth (Figure 39). Measure for screw length by referencing the laser mark on the drill where it meets the back end of the locking drill guide. Alternatively, detach the locking drill guide and use the depth gauge to measure for screw length.

Insert 3.5 mm Locking or Nonlocking Hexalobe Screws by connecting the T15 Stick Fit Hexalobe Driver (80-0760) to the Cannulated Quick Release Driver Handle, Large (80-2365).

Caution: Use the maximum number of screws based on the indication to reduce the risk of screw breakage during healing.

Note: Optional 4.0 mm Fully Threaded Cancellous Hexalobe Screws (3015-400XX) are available and can be used in place of 3.5 mm hexalobe screws.

Note: Optional 3.5 mm Locking Variable Angle Hexalobe Screws (3013-35XX) are available. See technique on page 42.

Confirm screw placement under fluoroscopy.

Closing and postoperative protocol are at the discretion of the surgeon.

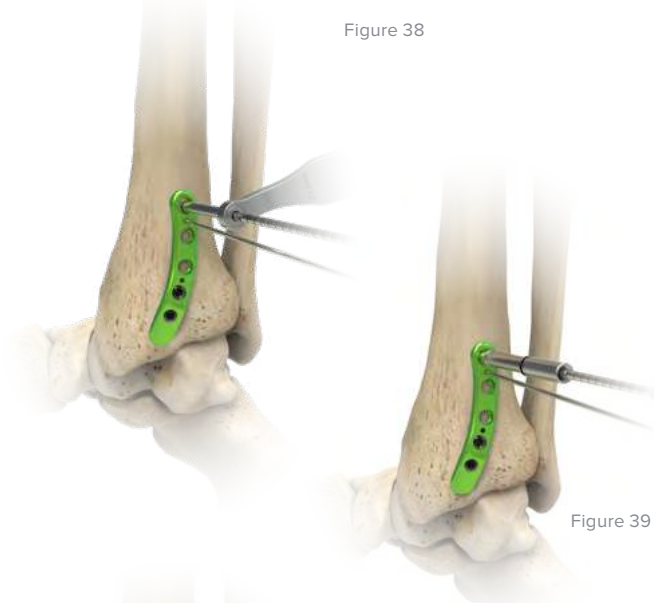

Figure 38

Figure 39

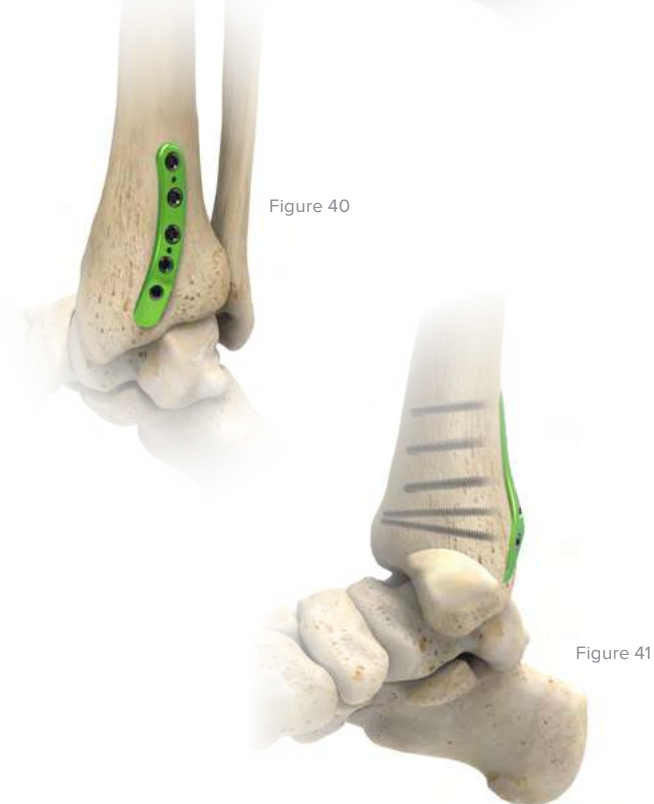
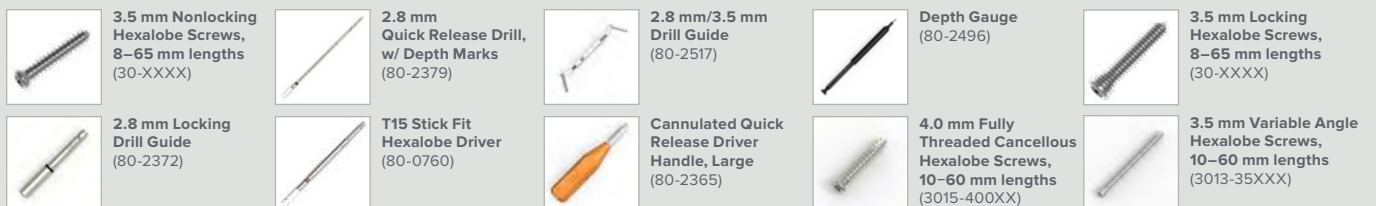

Figure 40

Figure 41



Medial Anti-Glide Plate Surgical Technique

Figure 42



Note: The Acumed Small Fragment Base System houses the screws and standard instrumentation needed for this procedure and must be used in conjunction with the Acumed Ankle Plating System 3.

1 Patient Positioning and Exposure

Position the patient supine and make a medial incision to expose the fracture of the tibia. After attaining appropriate position and exposure, care should be taken with vital soft tissue structures.

2 Fracture Reduction

Reduce the fracture using manual techniques. Provisional stability can be achieved utilizing forceps or .062" x 6" Guide Wires (WS-1607ST) and can be evaluated under fluoroscopy.

3 Plate Placement

Position the Medial Anti-Glide Plate 4-Hole (7007-0504) appropriately and fix provisionally with .062" x 6" Guide Wires (WS-1607ST) or .062" x 3" Threaded Plate Tacks (80-2430). Evaluation under fluoroscopy can confirm satisfactory placement of the plate.

Note: The 2.8 mm Locking Drill Guide (80-2372) can be attached to the plate to act as a handle and aid in provisional plate placement.

Figure 43

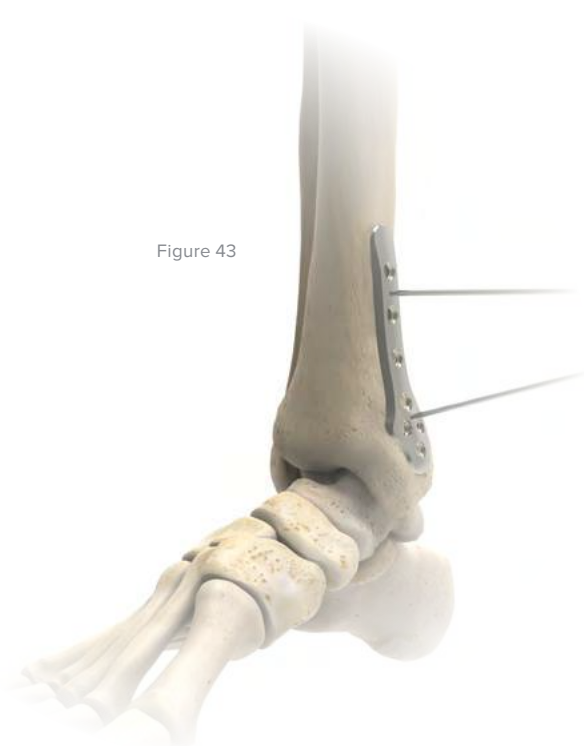

.062" x 6"
Guide Wire
(WS-1607ST)



Medial Anti-Glide
Plate 4-Hole
(7007-0504)



.062" x 3"
Threaded
Plate Tack
(80-2430)



2.8 mm Locking
Drill Guide
(80-2372)

Medial Anti-Glide Plate Surgical Technique [continued]

4 Distal 2.7 mm Hexalobe Screw Placement

The three most distal plate holes can accept 2.7 mm Hexalobe Screws. The most proximal hole in the distal cluster accepts 3.5 mm Hexalobe Screws.

Note: Care should be taken to avoid the joint space when inserting a screw in the most distal screw hole of the plate.

To insert 2.7 mm **Nonlocking** Hexalobe Screws (30-XXXX), drill with the 2.0 mm Quick Release Drill w/ Depth Marks (80-2378) through the 2.0 mm/2.7 mm Drill Guide (80-2516) to the desired depth. Measure for screw length by using the Depth Gauge (80-2496).

To insert 2.7 mm **Locking** Hexalobe Screws (30-XXXX), thread the 2.0 mm Locking Drill Guide into the desired hole. Drill through the 2.0 mm Locking Drill Guide (80-2371) with the 2.0 mm Quick Release Drill to the desired depth. Measure for screw length by referencing the laser mark on the drill where it meets the back end of the locking drill guide. Alternatively, detach the locking drill guide and use the depth gauge to measure for screw length.

Insert 2.7 mm Locking or Nonlocking Hexalobe Screws by connecting the T8 Stick Fit Hexalobe Driver (80-0759) to the Cannulated Quick Release Driver Handle, Medium (80-2364).

Note: Optional 2.7 mm Variable Angle Hexalobe Screws (3513-27XXX) are available. See technique on page 42.

Confirm screw placement under fluoroscopy.

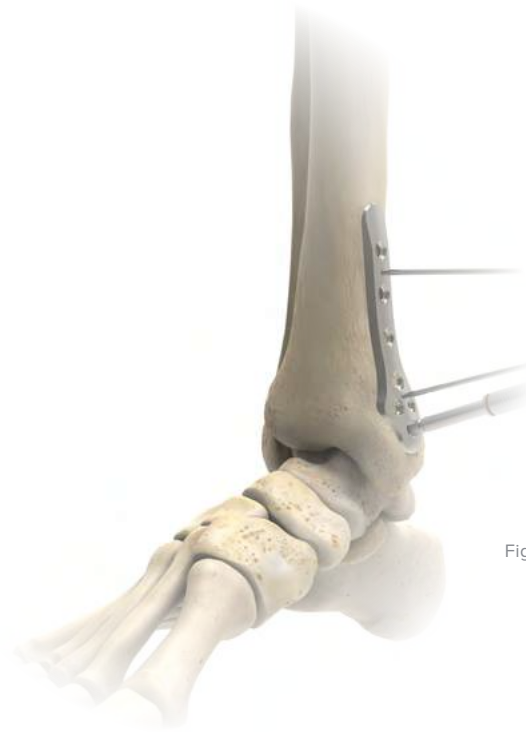
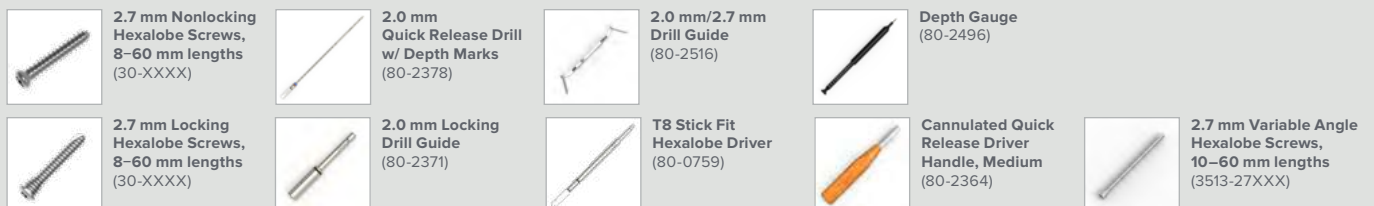

Figure 44



Medial Anti-Glide Plate Surgical Technique [continued]

Figure 45

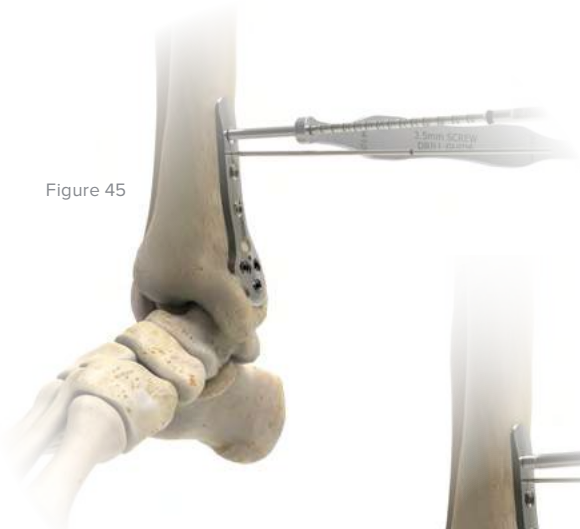

Figure 46

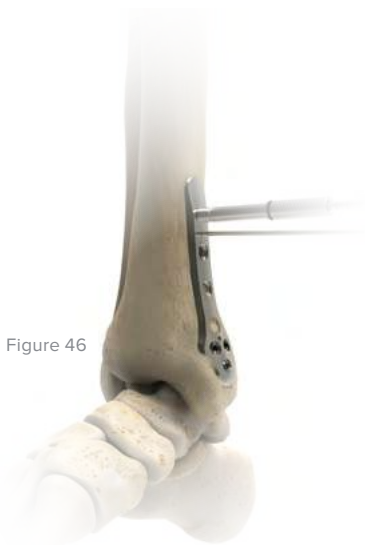

Figure 47



Figure 48



5 Proximal 3.5 mm Hexalobe Screw Placement

All proximal plate holes can accept 3.5 mm Hexalobe Screws.

To insert 3.5 mm **Nonlocking** Hexalobe Screws (30-XXXX), drill with the 2.8 mm Quick Release Drill, w/ Depth Marks (80-2379) through the 2.8 mm/3.5 mm Drill Guide (80-2517) to the desired depth (Figure 45). Measure for screw length by using the Depth Gauge (80-2496).

To insert 3.5 mm **Locking** Hexalobe Screws (30-XXXX), thread the 2.8 mm Locking Drill Guide (80-2372) into each plate hole. Drill through the 2.8 mm Locking Drill Guide with the 2.8 mm Quick Release Drill, w/ Depth Marks to the desired depth (Figure 46). Measure for screw length by referencing the laser mark on the drill where it meets the back end of the locking drill guide. Alternatively, detach the locking drill guide and use the depth gauge to measure for screw length.

Insert 3.5 mm Locking or Nonlocking Hexalobe Screws by connecting the T15 Stick Fit Hexalobe Driver (80-0760) to the Cannulated Quick Release Driver Handle, Large (80-2365).

Note: Optional 4.0 mm Fully Threaded Cancellous Hexalobe Screws (3015-400XX) are available and can be used in place of 3.5 mm hexalobe screws.

Note: Optional 3.5 mm Variable Angle Hexalobe Screws (3013-35XX) are available. See technique on page 42.

Confirm screw placement under fluoroscopy.

Closing and postoperative protocol are at the discretion of the surgeon.

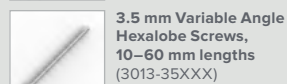
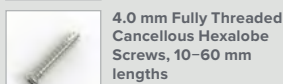
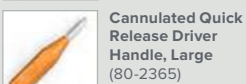
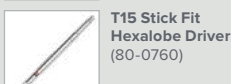
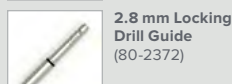
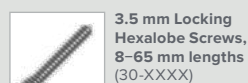
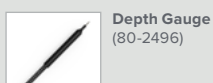
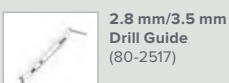
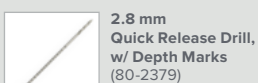
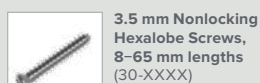

Hook Plate Surgical Technique

Note: The Acumed Small Fragment Base Set houses the screws and standard instrumentation needed for this procedure and must be used in conjunction with the Acumed Ankle Plating System 3.

1 Patient Positioning and Exposure

Position the patient supine and make a medial surgical incision to expose the fracture of the tibia, or make a lateral surgical incision to expose the fracture of the fibula.

After attaining appropriate position and exposure, care should be taken with vital soft tissue structures.

2 Fracture Reduction

Reduce the fracture using manual techniques. Provisional stability can be achieved utilizing forceps or .062" x 6" Guide Wires (WS-1607ST) and can be evaluated under fluoroscopy.

3 Plate Placement

If desired, the Hook Plate Reduction Handle Assembly (80-2317) can be attached to the most distal hole on the Hook Plate (7007-060X) in order to control plate placement (Figure 50). If utilized, the Hook Plate Reduction Handle should be removed after the placement of the first screw within the plate.

Note: The Hook Plate is designed to contour to the bone upon insertion of 2.7 mm Nonlocking Hexalobe Screws, 8–60 mm lengths (30-XXXX). Alternatively, the Hook Plate can be manually contoured prior to installation.

Position the Hook Plate appropriately and fix provisionally with .062" x 6" Guide Wires in the proximal end of the guide wire slots (Figure 51). These slots allow for additional compression after provisional fixation. The guide wire can be removed after installation of the first 2.7 mm Nonlocking Hexalobe Screw in the proximal compression slot.

Evaluation under fluoroscopy can confirm satisfactory placement of the plate.



Figure 49



Figure 50

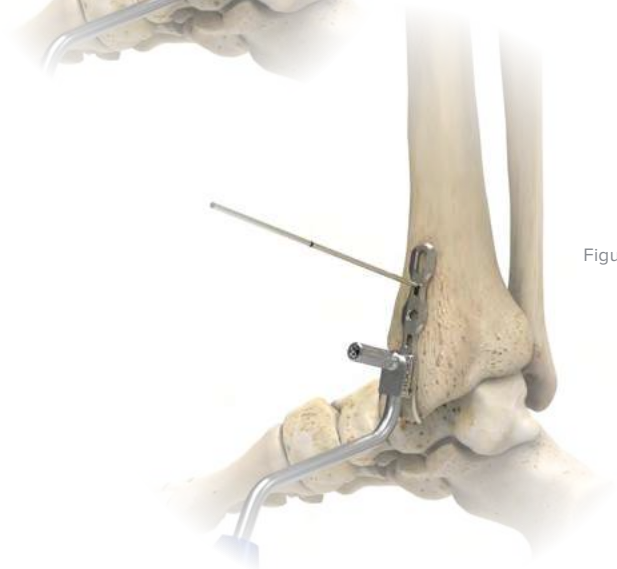

Figure 51



.062" x 6"
Guide Wire
(WS-1607ST)



Hook Plate
Reduction Handle
Assembly
(80-2317)



Hook Plate
(7007-060X)



2.7 mm Nonlocking
Hexalobe Screws,
8–60 mm lengths
(30-XXXX)

Hook Plate Surgical Technique [continued]

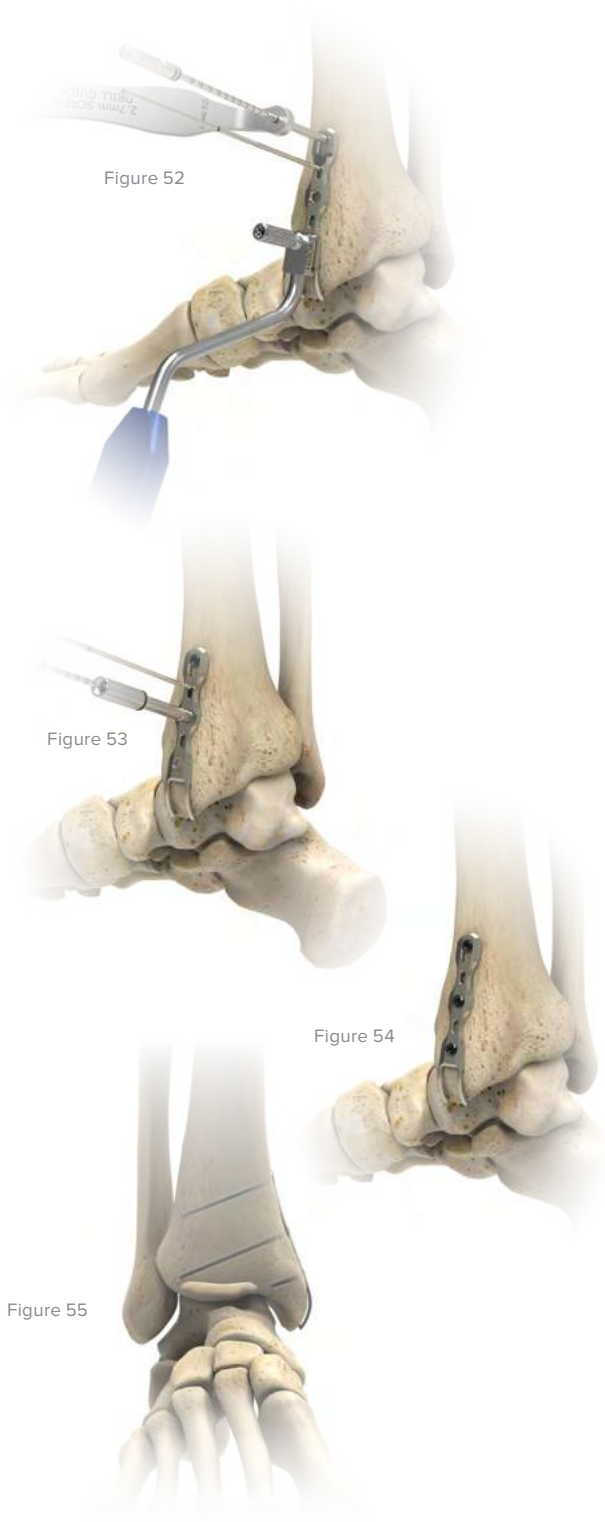

Figure 52

Figure 53

Figure 54

Figure 55

4 2.7 mm Hexalobe Screw Placement

All holes in the Hook Plate (70007-060X) can accept 2.7 mm hexalobe screws with the exception of the proximal slot, which only accepts a 2.7 mm Nonlocking Hexalobe Screw.

Warning: Care should be taken to avoid the joint space when inserting a screw in the most distal screw hole of the plate.

To insert 2.7 mm **Nonlocking** Hexalobe Screws (30-XXXX), drill with the 2.0 mm Quick Release Drill w/ Depth Marks (80-2378) through the 2.0 mm/2.7 mm Drill Guide (80-2516) to the desired depth (Figure 52). Measure for screw length by using the Depth Gauge (80-2496).

To insert 2.7 mm **Locking** Hexalobe Screws (30-XXXX), thread the 2.0 mm Locking Drill Guide (80-2371) into each plate hole. Drill through the 2.0 mm Locking Drill Guide with the 2.0 mm Quick Release Drill w/ Depth Marks to the desired depth (Figure 53). Measure for screw length by referencing the laser mark on the drill where it meets the back end of the locking drill guide. Alternatively, detach the locking drill guide and use the Depth Gauge to measure for screw length.

Insert 2.7 mm Locking and Nonlocking Hexalobe Screws by connecting the T8 Stick Fit Hexalobe Driver (80-0759) to the Cannulated Quick Release Driver Handle, Medium (80-2364).

Caution: Use the maximum number of screws based on the indication to reduce the risk of screw breakage during healing.

Note: Optional 2.7 mm Variable Angle Hexalobe Screws (3013-27XXX) are available. See technique on page 42.

Confirm screw placement under fluoroscopy.

Closing and postoperative protocol are at the discretion of the surgeon.



Locking Peg Hook Plate Surgical Technique

Note: The Acumed Small Fragment Base System houses the screws and standard instrumentation needed for this procedure and must be used in conjunction with the Acumed Ankle Plating System 3.

1 Patient Positioning and Exposure

Position the patient supine and make a medial surgical incision to expose the fracture of the tibia or make a lateral surgical incision to expose the fracture of the fibula.

After attaining appropriate position and exposure, care should be taken with vital soft tissue structures.

2 Fracture Reduction

Reduce the fracture using manual techniques. Provisional stability can be achieved utilizing forceps or .062" x 6" Guide Wires (WS-1607ST), and can be evaluated under fluoroscopy.

3 Plate Placement

The Hook Plate Reduction Handle Assembly (80-2317) can be attached to the most distal hole on the Locking Peg Hook Plate (7007-070X) in order to control plate placement, if desired (Figure 58). If utilized, the Hook Plate Reduction Handle should be removed after the placement of the first screw within the plate.

Note: The Locking Peg Hook Plate is designed to contour to the bone upon insertion of 2.7 mm **Nonlocking** Hexalobe Screws (30-XXXX). Alternatively, the Locking Peg Hook Plate can be manually contoured prior to installation.

Position the Locking Peg Hook Plate appropriately and fix provisionally with .062" x 6" Guide Wires in the proximal end of the guide wire slots (Figure 58). These slots allow for additional compression after provisional fixation. The guide wire can be removed after installation of the first 2.7 mm Nonlocking Hexalobe Screws in the proximal compression slot.

Evaluation under fluoroscopy can confirm satisfactory placement of the plate.



Figure 56



Figure 57

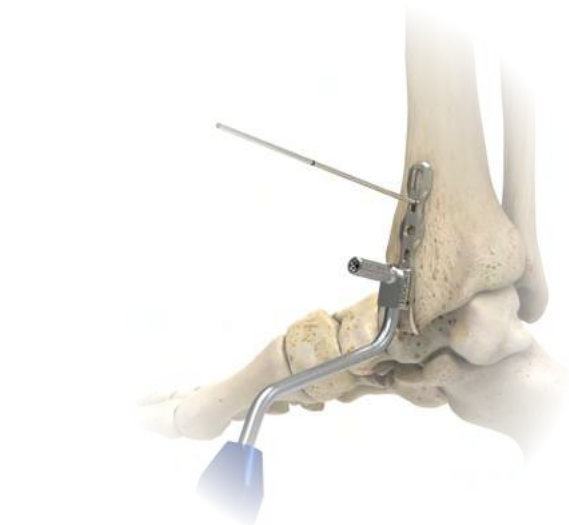

Figure 58



.062" x 6"
Guide Wire
(WS-1607ST)



Hook Plate
Reduction Handle
Assembly
(80-2317)



Locking Peg
Hook Plate
(7007-070X)



2.7 mm Nonlocking
Hexalobe Screws,
8-60 mm lengths
(30-XXXX)

Locking Peg Hook Plate Surgical Technique [continued]

4 Distal 2.3 mm Locking Cortical Peg Placement

Warning: Care should be taken to avoid placement of the 2.3 mm Locking Cortical Peg (3014-230XX) within the joint space.

Thread the 2.0 mm Locking Drill Guide / 2.3 mm Screws (80-2331) into the peg hole at the distal end of the plate. The Locking Cortical Pegs are available in 26 mm, 36 mm, and 46 mm lengths. Drill to the appropriate depth using the 2.0 mm Quick Release Drill w/ Depth Marks (80-2378) (Figure 60). Measure for peg length by referencing the laser mark on the drill where it meets the back end of the locking drill guide. Alternatively, detach the locking drill guide and use the Depth Gauge (80-2496) to measure for peg length. Insert the proper length 2.3 mm Locking Cortical Peg using the 1.5 mm Hex Driver Assembly (80-2335) (Figure 60).

Caution: There is a potential for screw/peg interface. This plate is designed to conform to the anatomy, which will impact the actual occurrence of interference. Under fluoroscopy, inspect the relative position of the peg and plate before screw placement.

Figure 59

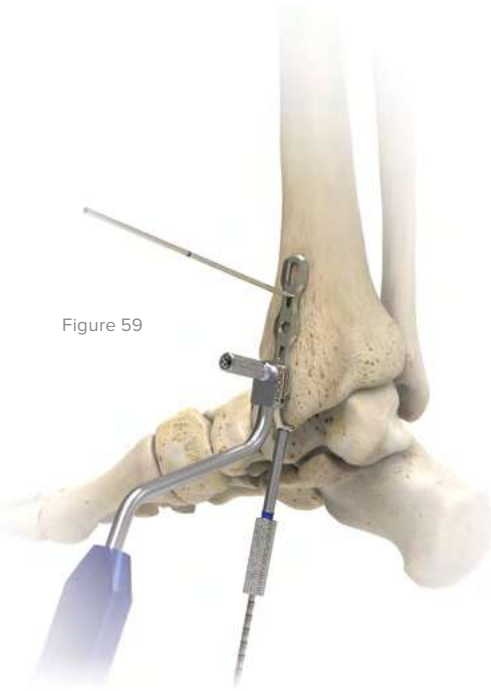
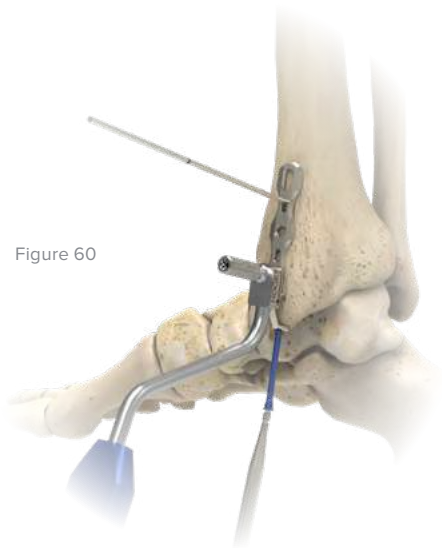

Figure 60



2.3 mm Locking Cortical Peg (3014-230XX)



2.0 mm Locking Drill Guide / 2.3 mm Screws (80-2331)



2.0 mm Quick Release Drill w/ Depth Marks (80-2378)



Depth Gauge (80-2496)



1.5 mm Hex Driver Assembly (80-2335)

Locking Peg Hook Plate Surgical Technique [continued]

5 Proximal 2.7 mm Hexalobe Screw Placement

The proximal holes in the Locking Peg Hook Plate can accept 2.7 mm hexalobe screws with the exception of the proximal slot, which only accepts a 2.7 mm nonlocking hexalobe screw.

Warning: Care should be taken to avoid the joint space when inserting a screw in the most distal screw hole of the plate.

Warning: Forcing the placement of screws against an interference condition may displace the fracture, peg, or plate.

To insert 2.7 mm **Nonlocking** Hexalobe Screws (30-XXXX), drill with the 2.0 mm Quick Release Drill w/ Depth Marks (80-2378) through the 2.0 mm/2.7 mm Drill Guide (80-2516) to the desired depth (Figure 61). Measure for screw length by using the Depth Gauge (80-2496).

To insert 2.7 mm **Locking** Hexalobe Screws (30-XXXX), thread the 2.0 mm Locking Drill Guide (80-2371) into each plate hole. Drill through the 2.0 mm Locking Drill Guide with the 2.0 mm Quick Release Drill w/ Depth Marks to the desired depth (Figure 63). Measure for screw length by referencing the laser mark on the drill where it meets the back end of the locking drill guide. Alternatively, detach the locking drill guide and use the Depth Gauge to measure for screw length.

Insert 2.7 mm Locking or Nonlocking Hexalobe screws by connecting the T8 Stick Fit Hexalobe Driver (80-0759) to Cannulated Quick Release Driver Handle, Medium (80-2364).

If free-hand drilling, the drill may encounter and skive off the peg, forcing the path and placement of the drill and screw. If the peg is encountered while drilling with the guide in place, read the drilled depth and place any screw shorter than the depth indicated, if available. Or, the physician can remove the drill guide and re-drill at a biased angle to avoid the interference, then place a 2.7 mm Nonlocking or 2.7 mm Variable Angle Locking Screw.

Do not place a 2.7 mm locking screw at an angle in the plate.

Caution: Use the maximum number of screws based on the indication to reduce the risk of screw breakage during healing.

Note: Optional 2.7 mm Variable Angle Hexalobe Screws (3013-27XX) are available. See technique on page 42.

Confirm screw placement under fluoroscopy.

Closing and postoperative protocol are at the discretion of the surgeon.

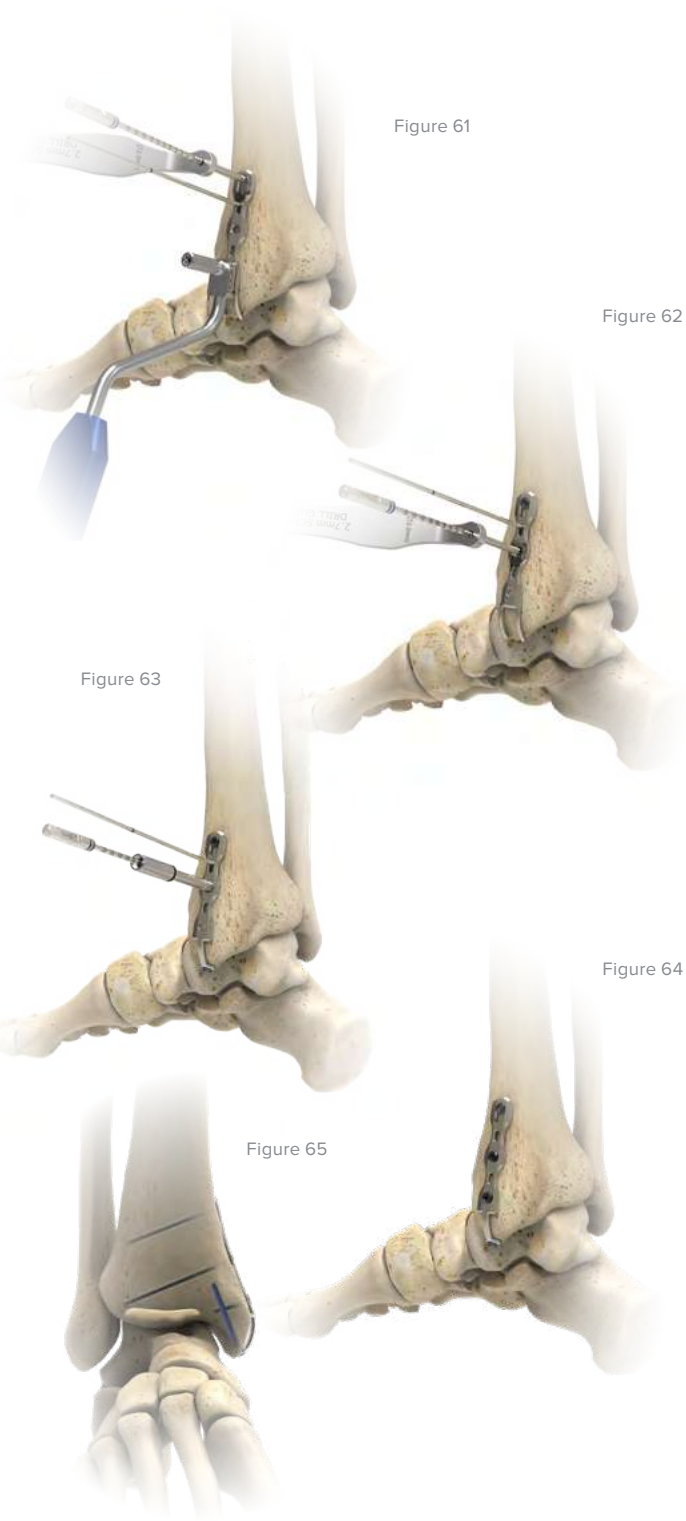

Variable Angle Screw Surgical Technique

Figure 66

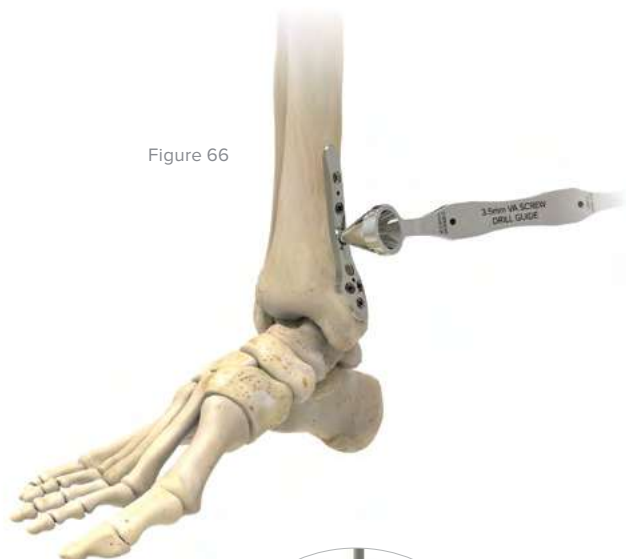

1 Place Variable Angle Drill Guide

To insert a 2.7 mm Variable Angle Hexalobe Screw 3013-27XXX off axis, insert the cone-shaped side of the 2.0 mm Variable Angle (VA) Drill Guide (80-2221) (Figure 66) or thread the 2.0 mm Threaded VA Drill Guide (80-2706) with the Threaded VA Drill Guide Driver (80-2708) (figures 67A and 67B) into the desired plate hole.

To insert a 3.5 mm Variable Angle Hexalobe Screw (3013-35XXX) off axis, insert the cone-shaped side of the 2.8 mm Variable Angle (VA) Drill Guide (80-2148) or thread the 2.8 mm Threaded VA Drill Guide (80-2707) with the Threaded VA Drill Guide Driver (80-2708) into the desired plate hole.

Caution: The 2.0 mm VA Drill Guide and 2.8 mm VA Drill Guide do not lock into the plate. To ensure the variable angle screws are installed as intended, the drill guide must be aligned with the axis of the screw hole.

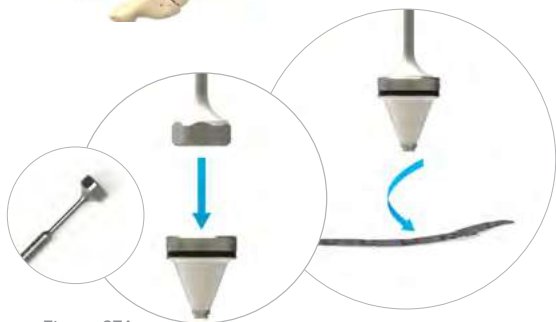

Figure 67A

Figure 67B



2.7 mm Variable Angle Hexalobe Screws (3013-27XXX)



2.0 mm Variable Angle (VA) Drill Guide (80-2221)



2.0 mm Threaded VA Drill Guide (80-2706)



Threaded VA Drill Guide Driver (80-2708)



3.5 mm Variable Angle Hexalobe Screws, 10–60 mm lengths (3013-35XXX)



2.8 mm Variable Angle (VA) Drill Guide (80-2148)



2.8 mm Threaded VA Drill Guide (80-2707)

Variable Angle Screw Surgical Technique [continued]

2 Drill

For 2.7 mm Variable Angle Hexalobe Screws (3013-27XX), drill through the 2.0 mm VA Drill Guide or VA Threaded Drill Guide (80-2706 or 80-2221) with the 2.0 mm Quick Release Drill w/ Depth Marks (80-2378) (Figures 68A and 68B).

For 3.5 mm Variable Angle Hexalobe Screws (3013-35XX), drill through the 2.8 mm VA Drill Guide or VA Threaded Drill Guide (80-2148 or 80-2707) with the 2.8 mm Quick Release Drill w/ Depth Marks (80-2379) (Figures 69A and 69B).

Use fluoroscopy to ensure the desired angle and depth have been achieved.

Caution: Avoid excessive re-drilling, particularly in poor quality bone, to prevent weakening of the screw-to-bone interface.

Warning: Excessive bending or contact with implants during use may cause the drill to be damaged or broken.

Figure 68A

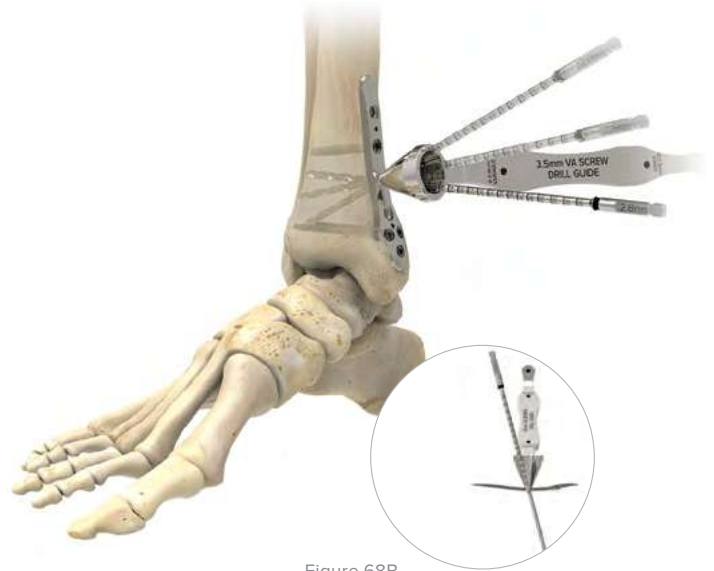

Figure 68B

Figure 69A

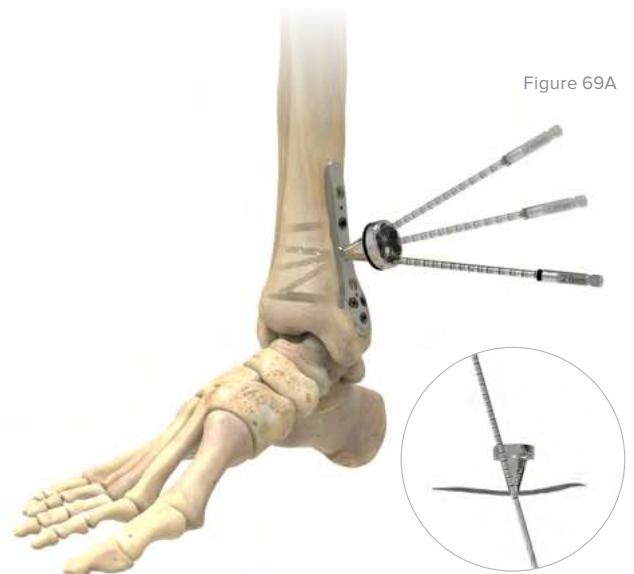

Figure 69B



2.7 mm Variable Angle Hexalobe Screws (3013-27XXX)



2.0 mm Threaded VA Drill Guide (80-2706)



VA Threaded Drill Guide (80-2221)



2.0 mm Quick Release Drill w/ Depth Marks (80-2378)



3.5 mm Variable Angle Hexalobe Screws, 10–60 mm lengths (3013-35XXX)



2.8 mm Variable Angle (VA) Drill Guide (80-2148)



VA Threaded Drill Guide (80-2707)



2.8 mm Quick Release Drill, w/ Depth Marks (80-2379)

Variable Angle Screw Surgical Technique [continued]

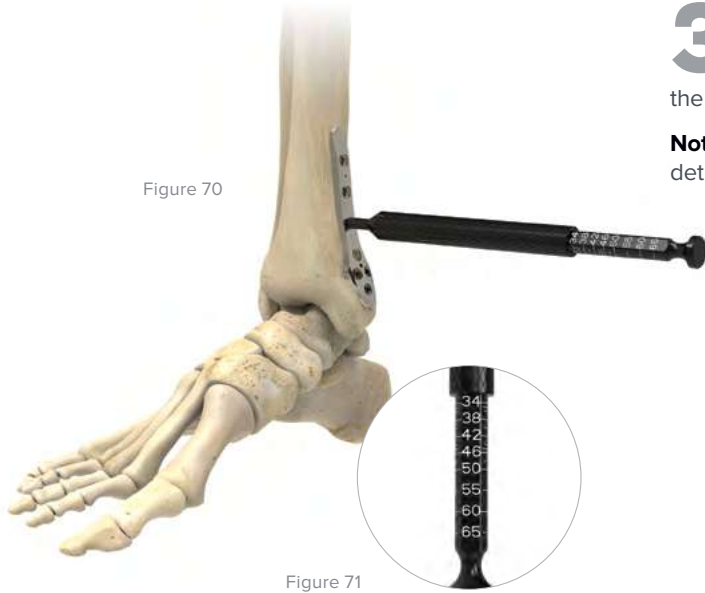

3 Measure Screw Length

Use the Depth Gauge (80-2496) to measure through the drilled hole to determine the correct length of screw.

Note: The cone side of the VA drill guides may not be used to determine screw length.



Variable Angle Screw Surgical Technique [continued]

4 Insert Variable Angle Screw

Note: Final tightening of the 2.7 mm and 3.5 mm variable angle hexalobe screws must be done manually and not under power. The Torque Limiting Quick Connect ensures a consistent insertion torque to provide a uniform screw-plate interface and may prevent overtightening of the screw. See below for the torque limit for each screw.

To insert a 2.7 mm Variable Angle Hexalobe Screw (3013-27XXX), assemble the 1.70 N•m Torque Limiting Quick Connect (80-2366) to the Handle for Torque Limiting Quick Connect (80-2368). Connect the T8 Stick Fit Hexalobe Driver (80-0759) to the Torque Limiting Quick Connect assembly.

To insert a 3.5 mm Variable Angle Hexalobe Screw (3013-35XXX), assemble the 2.26 N•m Torque Limiting Quick Connect (80-2367) to the Handle for Torque Limiting Quick Connect. Connect the T15 Stick Fit Hexalobe Driver (80-0760) to the Torque Limiting Quick Connect assembly.

Advance the screw by hand until achieving an audible click and/or tactile feedback. Final tightening should be completed with the Torque Limiting Handle, which is designed to provide a secure lock between the plate and screw. Upon final seating, confirm proper screw placement and screw length under fluoroscopy.

Note: Do not use a Torque Limiting Quick Connect for screw removal.

Caution: Use the maximum number of screws based on the indication to reduce the risk of screw breakage during healing.

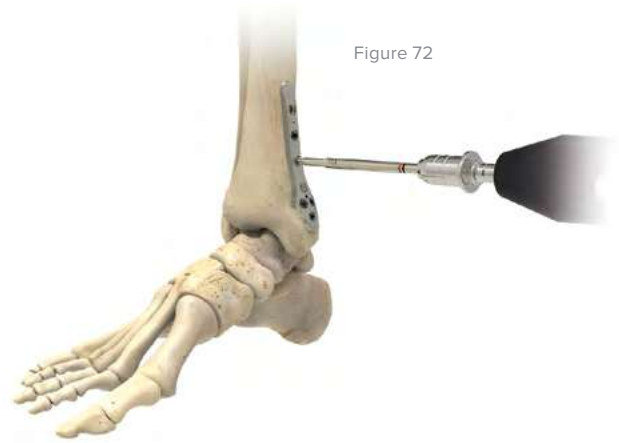
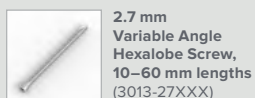

Figure 72

Screw	Torque Limit	Color Band
2.7 mm Variable Angle Hexalobe Screw (3013-27XXX)	1.70 N•m	Brown
3.5 mm Variable Angle Hexalobe Screw (3013-35XXX)	2.26 N•m	Black



2.7 mm Variable Angle Hexalobe Screw, 10-60 mm lengths (3013-27XXX)



1.70 N-m Torque Limiting Quick Connect (80-2366)



Handle for Torque Limiting Quick Connect (80-2368)



T8 Stick Fit Hexalobe Driver (80-0759)



3.5 mm Variable Angle Hexalobe Screw, 10-65 mm lengths (3013-35XXX)



2.26 N-m Torque Limiting Quick Connect (80-2367)



T15 Stick Fit Hexalobe Driver (80-0760)

4.0 mm Cannulated Screw Surgical Technique

Figure 73



1 Patient Positioning and Exposure

Position the patient supine and make a medial surgical incision to expose the fracture of the tibia.

2 Fracture Reduction

Reduce the fracture using manual techniques. Provisional stability can be achieved utilizing forceps or 1.3 mm Non-threaded Guide Wires 150 mm (80-2039), and can be evaluated under fluoroscopy.

Figure 74

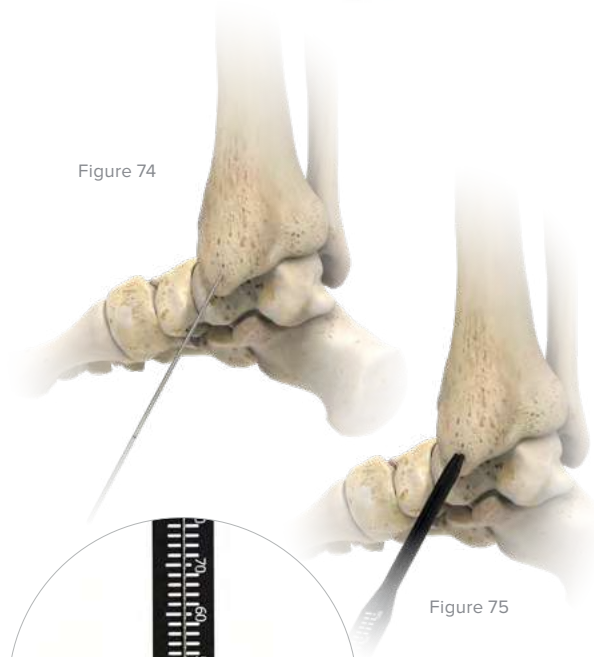

Figure 75

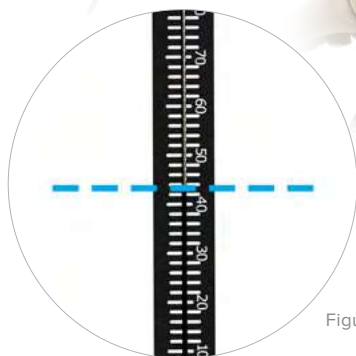

Figure 76

3 Determine Screw Length

Insert the 1.3 mm Non-threaded Guide Wire, 150 mm so that it is perpendicular to the fracture line and occupies the future position of the lag screw (Figure 74). Measure for screw length by sliding the 4.0/4.5 mm Screw Sizer (80-2080) over the guide wire (Figure 75). Read the length directly from the 4.0/4.5 mm Screw Sizer by noting the location of the end of the guide wire in relation to numerals and hash marks on the device (Figure 76). This measurement must be taken with the supplied guide wire.



1.3 mm
Non-threaded
Guide Wire, 150 mm
(80-2039)



4.0/4.5 mm
Screw Sizer
(80-2080)

4.0 mm Cannulated Screw Surgical Technique [continued]

4 4.0 mm Cannulated Screw Placement

Remove the 4.0/4.5 mm Screw Sizer (80-2080) and slide the 2.7 mm Cannulated Drill, Quick Connect (80-2075) over the guide wire and through the 2.0/2.7 mm Drill Guide (80-2516) (Figure 71). Drill to the desired depth.

Note: If the guide wire becomes stuck in the cannulated drill following drilling, it may be removed using another guide wire from the system.

Optional Screw Insertion with Washer

Place the Cannulated Screw Washer 7.0 mm OD x 3.6 mm ID (7003-07036) onto the screw before insertion.

Connect the 2.5 mm Cannulated Hex Driver, Quick Connect (80-2073) to the Cannulated Quick Release Driver Handle, Large (80-2365) and insert the appropriate length 4.0 mm Cannulated Screw (300X-400XX) over the guide wire (Figure 78). The screw must lie with its threads completely beyond the fracture line to achieve the appropriate compression.

Confirm screw placement under fluoroscopy.

Closing and postoperative protocol are at the discretion of the surgeon.

5 Removal

The cannulated screws are designed to be removed from the body when necessary. After surgically obtaining access to the head of the screw, use the 2.5 mm Cannulated Hex Driver, Quick Connect (80-2073) to remove the screw by engaging the driver tip within the hex recess in the screw head and turning counterclockwise.

Note: It may be necessary to clean out bony ingrowth from the head of the screw using a surgical pick or guide wire tip prior to inserting the driver tip.

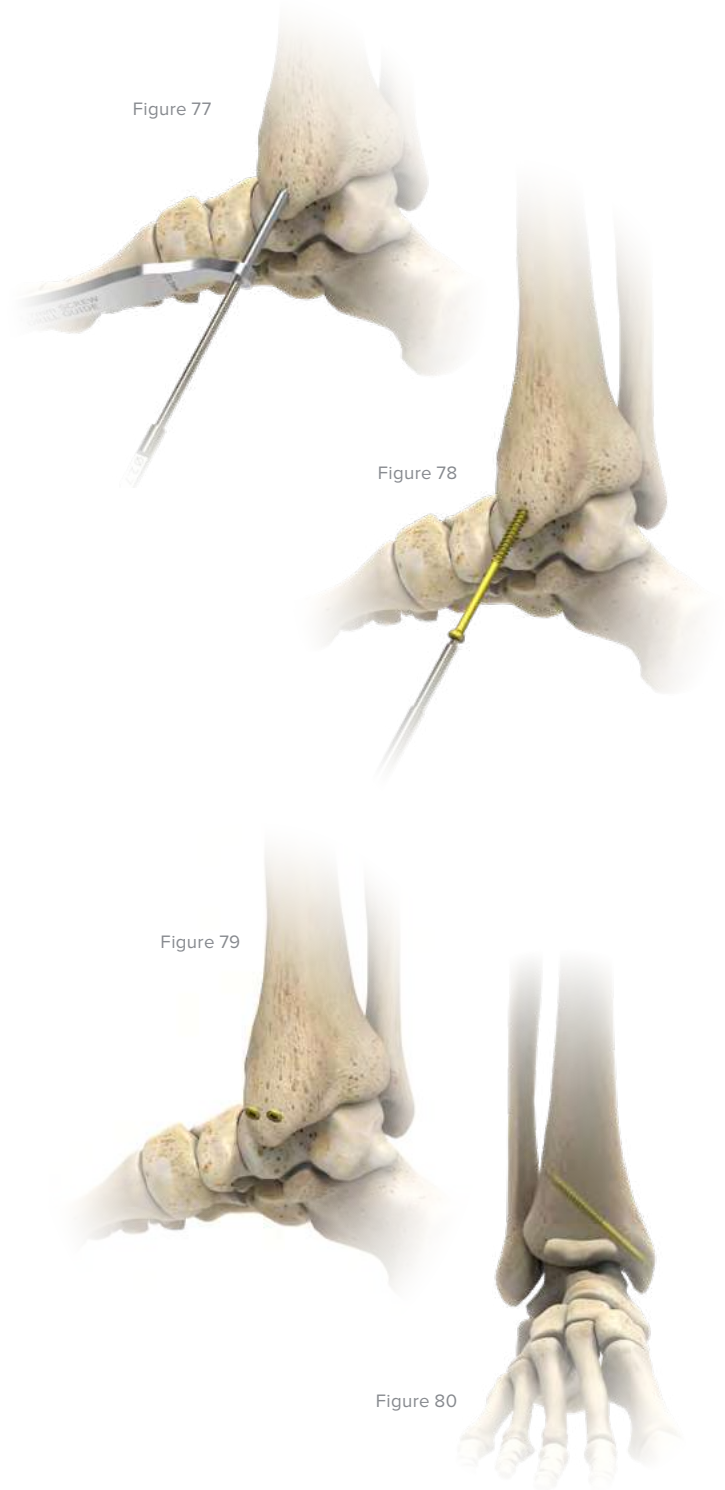

4.0/4.5 mm
Screw Sizer
(80-2080)



2.7 mm Cannulated
Drill, Quick Connect
(80-2075)



2.0/2.7 mm
Drill Guide
(80-2516)



Cannulated Screw
Washer 7.0 mm OD
x 3.6 mm ID
(7003-07036)



2.5 mm Cannulated
Hex Driver, Quick
Connect
(80-2073)



Cannulated Quick
Release Driver
Handle, Large
(80-2365)



4.0 mm
Cannulated Screw
(300X-400XX)

Ordering Information

Tray Components

Implants

1	Lateral Fibula Plate 4-Hole, Left	7007-0104L	15	Posterolateral Fibula Plate 5-Hole, Left	7007-0205L
2	Lateral Fibula Plate 4-Hole, Right	7007-0104R	16	Posterolateral Fibula Plate 5-Hole, Right	7007-0205R
3	Lateral Fibula Plate 5-Hole, Left	7007-0105L	17	Posterolateral Fibula Plate 6-Hole, Left	7007-0206L
4	Lateral Fibula Plate 5-Hole, Right	7007-0105R	18	Posterolateral Fibula Plate 6-Hole, Right	7007-0206R
5	Lateral Fibula Plate 6-Hole, Left	7007-0106L	19	Posterolateral Fibula Plate 7-Hole, Left	7007-0207L
6	Lateral Fibula Plate 6-Hole, Right	7007-0106R	20	Posterolateral Fibula Plate 7-Hole, Right	7007-0207R
7	Lateral Fibula Plate 7-Hole, Left	7007-0107L	21	Posterolateral Distal Tibia Plate 3-Hole, Left	7007-0303L
8	Lateral Fibula Plate 7-Hole, Right	7007-0107R	22	Posterolateral Distal Tibia Plate 3-Hole, Right	7007-0303R
9	Lateral Fibula Plate 9-Hole, Left	7007-0109L	23	Posterolateral Distal Tibia Plate 4-Hole, Left	7007-0304L
10	Lateral Fibula Plate 9-Hole, Right	7007-0109R	24	Posterolateral Distal Tibia Plate 4-Hole, Right	7007-0304R
11	Posterolateral Fibula Plate 3-Hole, Left	7007-0203L	25	Posteromedial Distal Tibia Plate 3-Hole, Left	7007-0403L
12	Posterolateral Fibula Plate 3-Hole, Right	7007-0203R	26	Posteromedial Distal Tibia Plate 3-Hole, Right	7007-0403R
13	Posterolateral Fibula Plate 4-Hole, Left	7007-0204L	27	Medial Anti-Glide Plate 4-Hole	7007-0504
14	Posterolateral Fibula Plate 4-Hole, Right	7007-0204R			

Instruments

28	Lateral Fibula Targeting Block, Left	80-2310	31	Posterolateral Fibula Targeting Block, Right	80-2313
29	Lateral Fibula Targeting Block, Right	80-2311	32	Targeting Block Locking Bolt	80-2315
30	Posterolateral Fibula Targeting Block, Left	80-2312	33	2.0 mm Drill Guide	80-2314

Sterile Implants*

Lateral Fibula Plate 11-Hole, Left (optional)	7007-0111L-S	Lateral Fibula Plate 13-Hole, Left (optional)	7007-0113L-S
Lateral Fibula Plate 11-Hole, Right (optional)	7007-0111R-S	Lateral Fibula Plate 13-Hole, Right (optional)	7007-0113R-S

*Implants and screws are also available sterile-packed. Add an "-S" at end of product number for sterile product. For more details on sterile products, including pricing, contact our Business Services Department toll free at 888.627.9957.

Reference the Acumed Small Fragment Base Set Surgical Technique (TMA10-01) for the list of implants, instruments, and screws included within that set.

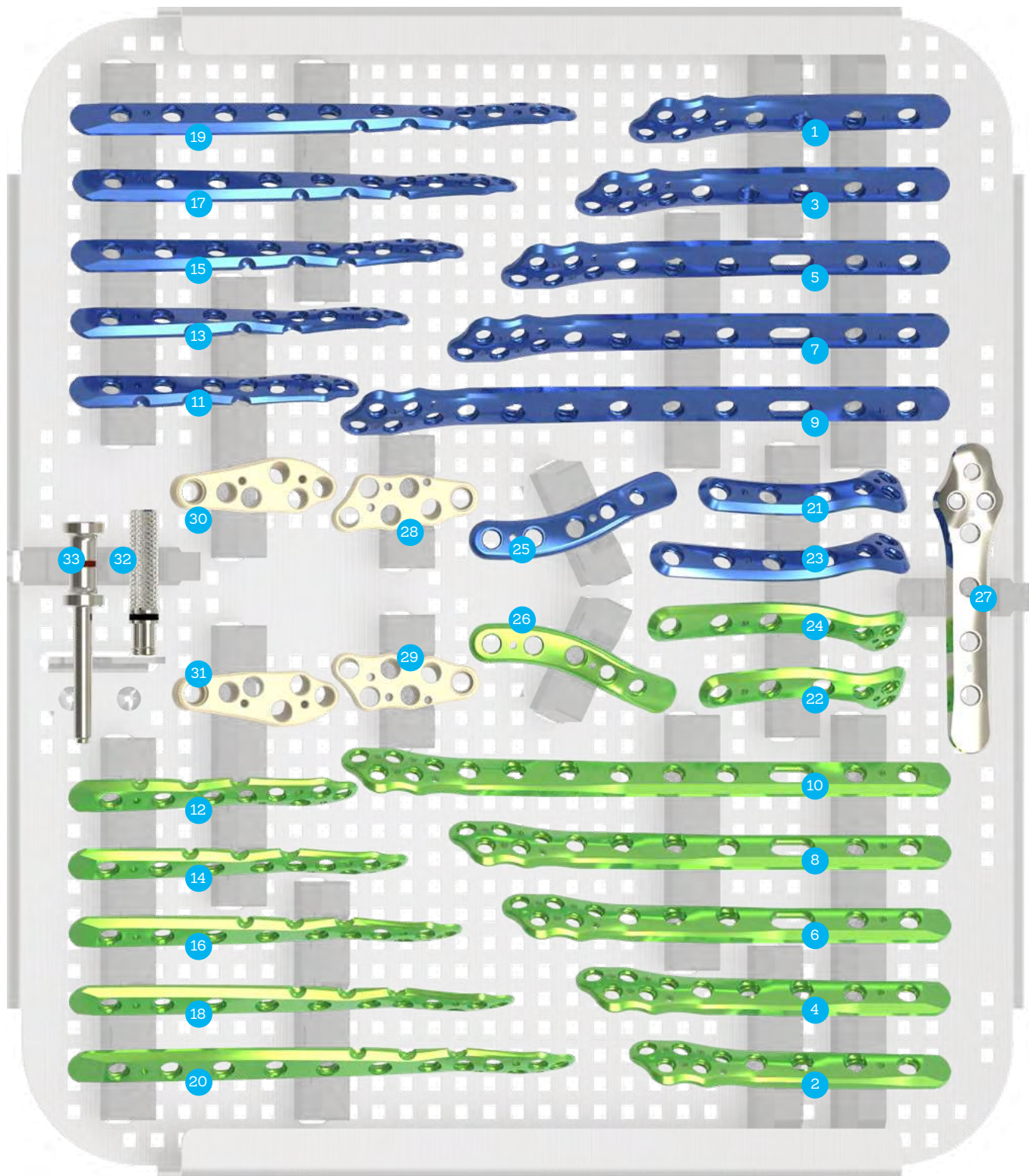

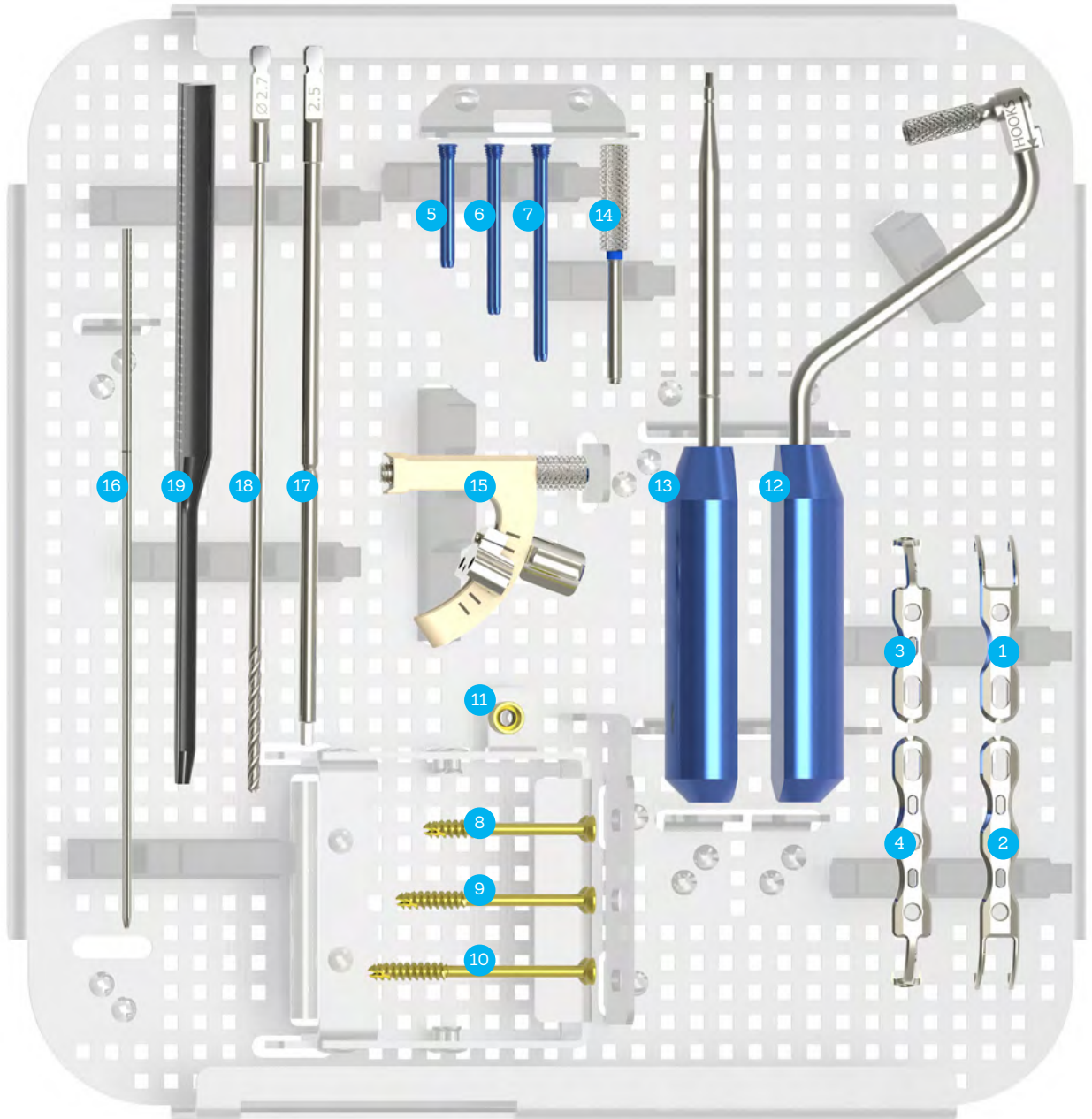

Ordering Information [continued]

Tray Components

1 4.0 mm Cannulated Screw Short Thread Caddy

4.0 mm x 10 mm Cannulated Screw, Short Thread	3005-40010	4.0 mm x 40 mm Cannulated Screw, Short Thread	3005-40040
4.0 mm x 12 mm Cannulated Screw, Short Thread	3005-40012	4.0 mm x 42 mm Cannulated Screw, Short Thread	3005-40042
4.0 mm x 14 mm Cannulated Screw, Short Thread	3005-40014	4.0 mm x 44 mm Cannulated Screw, Short Thread	3005-40044
4.0 mm x 16 mm Cannulated Screw, Short Thread	3005-40016	4.0 mm x 46 mm Cannulated Screw, Short Thread	3005-40046
4.0 mm x 18 mm Cannulated Screw, Short Thread	3005-40018	4.0 mm x 48 mm Cannulated Screw, Short Thread	3005-40048
4.0 mm x 20 mm Cannulated Screw, Short Thread	3005-40020	4.0 mm x 50 mm Cannulated Screw, Short Thread	3005-40050
4.0 mm x 22 mm Cannulated Screw, Short Thread	3005-40022	4.0 mm x 52 mm Cannulated Screw, Short Thread	3005-40052
4.0 mm x 24 mm Cannulated Screw, Short Thread	3005-40024	4.0 mm x 54 mm Cannulated Screw, Short Thread	3005-40054
4.0 mm x 26 mm Cannulated Screw, Short Thread	3005-40026	4.0 mm x 56 mm Cannulated Screw, Short Thread	3005-40056
4.0 mm x 28 mm Cannulated Screw, Short Thread	3005-40028	4.0 mm x 58 mm Cannulated Screw, Short Thread	3005-40058
4.0 mm x 30 mm Cannulated Screw, Short Thread	3005-40030	4.0 mm x 60 mm Cannulated Screw, Short Thread	3005-40060
4.0 mm x 32 mm Cannulated Screw, Short Thread	3005-40032	4.0 mm x 64 mm Cannulated Screw, Short Thread	3005-40064
4.0 mm x 34 mm Cannulated Screw, Short Thread	3005-40034	4.0 mm x 68 mm Cannulated Screw, Short Thread	3005-40068
4.0 mm x 36 mm Cannulated Screw, Short Thread	3005-40036	4.0 mm x 72 mm Cannulated Screw, Short Thread	3005-40072
4.0 mm x 38 mm Cannulated Screw, Short Thread	3005-40038		

Ordering Information [continued]

Tray Components			
2 4.0 mm Cannulated Screw Long Thread Caddy			
4.0 mm x 16 mm Cannulated Screw, Long Thread	3006-40016	4.0 mm x 42 mm Cannulated Screw, Long Thread	3006-40042
4.0 mm x 18 mm Cannulated Screw, Long Thread	3006-40018	4.0 mm x 44 mm Cannulated Screw, Long Thread	3006-40044
4.0 mm x 20 mm Cannulated Screw, Long Thread	3006-40020	4.0 mm x 46 mm Cannulated Screw, Long Thread	3006-40046
4.0 mm x 22 mm Cannulated Screw, Long Thread	3006-40022	4.0 mm x 48 mm Cannulated Screw, Long Thread	3006-40048
4.0 mm x 24 mm Cannulated Screw, Long Thread	3006-40024	4.0 mm x 50 mm Cannulated Screw, Long Thread	3006-40050
4.0 mm x 26 mm Cannulated Screw, Long Thread	3006-40026	4.0 mm x 52 mm Cannulated Screw, Long Thread	3006-40052
4.0 mm x 28 mm Cannulated Screw, Long Thread	3006-40028	4.0 mm x 54 mm Cannulated Screw, Long Thread	3006-40054
4.0 mm x 30 mm Cannulated Screw, Long Thread	3006-40030	4.0 mm x 56 mm Cannulated Screw, Long Thread	3006-40056
4.0 mm x 32 mm Cannulated Screw, Long Thread	3006-40032	4.0 mm x 58 mm Cannulated Screw, Long Thread	3006-40058
4.0 mm x 34 mm Cannulated Screw, Long Thread	3006-40034	4.0 mm x 60 mm Cannulated Screw, Long Thread	3006-40060
4.0 mm x 36 mm Cannulated Screw, Long Thread	3006-40036	4.0 mm x 64 mm Cannulated Screw, Long Thread	3006-40064
4.0 mm x 38 mm Cannulated Screw, Long Thread	3006-40038	4.0 mm x 68 mm Cannulated Screw, Long Thread	3006-40068
4.0 mm x 40 mm Cannulated Screw, Long Thread	3006-40040	4.0 mm x 72 mm Cannulated Screw, Long Thread	3006-40072
3 4.0 mm Washer			
Cannulated Screw Washer 7.0 mm OD x 3.6 mm ID	7003-07036		

Ordering Information [continued]

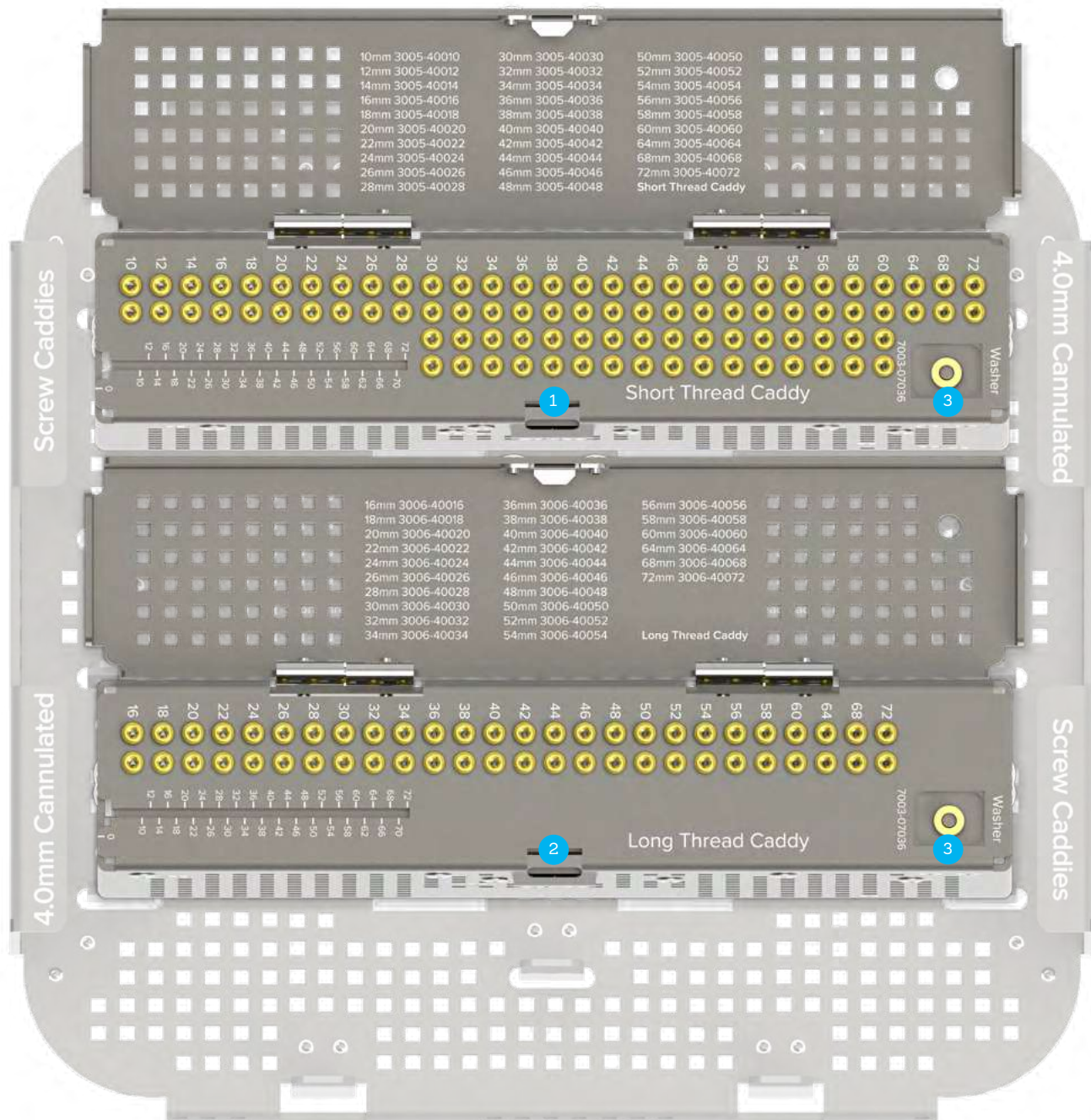

References

1. Switaj P, Weatherford B, Fuchs D, Rosenthal B, Pang E, Kadakia AR. Evaluation of posterior malleolar fractures and the posterior pilon variant in operatively treated ankle fractures. *Foot Ankle Int*. Published online June 18, 2014.
2. Duan X, Kadakia AR. Operative treatment of posterior malleolar fractures. *Open Orthop J*. 2017;11:732–742.
3. Wheeless C. Technique of syndesmotic fixation. Wheeless Textbook of Orthopaedics website. http://www.wheelessonline.com/ortho/technique_of_snydesmotic_fixation. Published December 11, 2014.
4. Wheeler DL, McLoughlin SW. Biomechanical assessment of compression screws. *Clin Orthop Relat Res*. 1998;350:237–245.



Acumed Headquarters
5885 NE Cornelius Pass Road
Hillsboro, OR 97124
Office: +1.888.627.9957
Office: +1.503.627.9957
Fax: +1.503.520.9618
www.acumed.net

These materials contain information about products that may or may not be available in any particular country or may be available under different trademarks in different countries. The products may be approved or cleared by governmental regulatory organizations for sale or use with different indications or restrictions in different countries. Products may not be approved for use in all countries. Nothing contained in these materials should be construed as a promotion or solicitation for any product or for the use of any product in a particular way that is not authorized under the laws and regulations of the country where the reader is located. Nothing in these materials should be construed as a representation or warranty as to the efficacy or quality of any product, nor the appropriateness of any product to treat any specific condition. Physicians may direct questions about the availability and use of the products described in these materials to their authorized Acumed distributor. Specific questions patients may have about the use of the products described in these materials or the appropriateness for their own conditions should be directed to their own physician.

LEX00-06-K | Effective: 2020/04 | © 2020 Acumed® LLC